

## Duality and higher derivative terms in M theory

---

**Michael B. Green**

*DAMTP*

*Wilberforce Road, Cambridge CB3 0WA, U.K.*

*E-mail: m.b.green@damtp.cam.ac.uk*

**Pierre Vanhove**

*Service de Physique Théorique, CEA/DSM/PhT, CEA/Saclay*

*91191 Gif-sur-Yvette, France*

*E-mail: pierre.vanhove@cea.fr*

ABSTRACT: Dualities of M-theory are used to determine the exact dependence on the coupling constant of the  $D^6 \mathcal{R}^4$  interaction of the IIA and IIB superstring effective action. Upon lifting to eleven dimensions this determines the coefficient of the  $D^6 \mathcal{R}^4$  interaction in eleven-dimensional M-theory. These results are obtained by considering the four-graviton two-loop scattering amplitude in eleven-dimensional supergravity compactified on a circle and on a two-torus — extending earlier results concerning lower-derivative interactions. The torus compactification leads to an interesting  $SL(2, \mathbf{Z})$ -invariant function of the complex structure of the torus (the IIB string coupling) that satisfies a Laplace equation with a source term on the fundamental domain of moduli space. The structure of this equation is in accord with general supersymmetry considerations and immediately determines tree-level and one-loop contributions to  $D^6 \mathcal{R}^4$  in perturbative IIB string theory that agree with explicit string calculations, and two-loop and three-loop contributions that have yet to be obtained in string theory. The complete solution of the Laplace equation contains infinite series' of single  $D$ -instanton and double  $D$ -instanton contributions, in addition to the perturbative terms. General considerations of the higher loop diagrams of eleven-dimensional supergravity suggest extensions of these results to interactions of higher order in the low energy expansion.

KEYWORDS: M-Theory, String Duality.

---

## Contents

<b>1. Introduction</b>	<b>1</b>
<b>2. Review of two-loop supergravity and the <math>D^4\mathcal{R}^4</math> interaction</b>	<b>6</b>
2.1 Evaluation of the two-loop amplitude on $\mathcal{T}^n$	7
<b>3. <math>D^6\mathcal{R}^4</math> interaction from two-loop supergravity</b>	<b>12</b>
3.1 Expansion of two-loop integrals	12
<b>4. Compactification on a circle</b>	<b>13</b>
<b>5. Compactification on <math>\mathcal{T}^2</math></b>	<b>15</b>
5.1 Evaluation of integral	15
5.2 Inhomogeneous Laplace equation	19
5.3 Properties of $\mathcal{E}_{(\frac{3}{2}, \frac{3}{2})}(\Omega, \bar{\Omega})$	20
5.4 The three-loop term	22
<b>6. Higher Loops and Higher Order Interactions</b>	<b>24</b>
6.1 Dimensional analysis and higher order terms	25
<b>7. Summary and discussion of the eleven-dimensional limit</b>	<b>29</b>
<b>A. Review of tree-level string amplitude and expansion of <math>Z_s(\Omega, \bar{\Omega})</math></b>	<b>31</b>
<b>B. The dictionary between supergravity and superstring theories</b>	<b>32</b>
<b>C. Laplace equations</b>	<b>33</b>
C.1 Laplace equation for $A(\tau, \bar{\tau})$	33
C.2 Laplace equation for $\mathcal{Z}_{(s,s)}$	34
C.3 Laplace equation for the lattice sum	34

---

## 1. Introduction

The low-energy expansion of the effective action of the type II superstring theories is an infinite power series in  $\alpha' = l_s^2$  (where  $l_s$  is the string distance scale) consisting of higher derivative interactions, which are strongly constrained by maximal supersymmetry and  $SL(2, \mathbf{Z})$  invariance. The leading term defines the classical theory that contains the ten-dimensional Einstein–Hilbert action,  $l_s^{-8} \int d^{10}x e^{-2\phi} \sqrt{-g} R$ , together with many other interactions of the same dimension involving other fields. These terms are uniquely specified by imposing IIB  $N = 2$  supersymmetry.

The absence of an off-shell superspace formalism for ten-dimensional extended supersymmetry indicates that the theory is very constrained, which makes it both difficult and interesting to determine the higher derivative interactions. Various duality and supersymmetry arguments have been used to determine the form of some of the low order terms [2–6], [7]. For example, the first term in the derivative expansion beyond the Einstein–Hilbert term that contributes to four-graviton scattering has the form

$$l_s^{-2} \int d^{10}x \sqrt{-g} e^{-\phi/2} Z_{\frac{3}{2}}^{(0,0)} \mathcal{R}^4, \tag{1.1}$$

in string frame. The dilaton factor  $e^{-\phi/2}$  is again absent in Einstein frame. The symbol  $\mathcal{R}^4$  denotes a specific contraction of four Weyl tensors that arises from the leading behaviour in the low energy expansion of the four-graviton amplitude. The function  $Z_{\frac{3}{2}}^{(0,0)}(\Omega, \bar{\Omega})$  is a modular form with holomorphic and anti-holomorphic weights  $(0, 0)$ . It is a function of the complex coupling  $\Omega = \Omega_1 + i\Omega_2$ , where  $\Omega_2 = e^{-\phi}$  and  $\Omega_1 = C^{(0)}$  (the Ramond–Ramond zero-form). There are very many other interactions of the same dimension, that are related by supersymmetry to the  $\mathcal{R}^4$  interaction. Many of these may be inferred by using a linearized on-shell superfield approximation in which the interactions are given by integrals over sixteen Grassmann components, which is half the dimension of the type II superspace. However, it has not yet been possible to determine the full nonlinear action at this order in the derivative expansion.

One of the methods for studying these higher order terms makes use of the duality between eleven-dimensional supergravity compactified on a two-torus in the limit of zero volume and ten-dimensional type II string theory, which was originally considered in the context of the classical theory [8, 9], based on properties of the supersymmetrised Einstein–Hilbert action. The IIB coupling constant is identified with the complex structure,  $\Omega$ , of the two-torus, so the  $SL(2, \mathbf{Z})$  duality symmetry of the string theory originates from the geometric invariance of supergravity under large diffeomorphisms of the torus. Quantum corrections were considered in [3–5], where it was shown that the one-loop contributions to four-graviton scattering in eleven-dimensional supergravity on  $T^2$  determine the form of the coefficient of the  $\mathcal{R}^4$  term,  $Z_{\frac{3}{2}}^{(0,0)}$ , and its supersymmetric partners. This was generalized to the analysis of two-loop four-graviton scattering in eleven-dimensional supergravity amplitudes compactified on  $T^2$  in [10]. The leading term in the low energy limit determined the dilaton dependent function,  $Z_{\frac{5}{2}}^{(0,0)}(\Omega, \bar{\Omega})$  of the

$$l_s^2 \int d^{10}x \sqrt{-g} e^{\phi/2} Z_{\frac{5}{2}}^{(0,0)} D^4 \mathcal{R}^4 \tag{1.2}$$

interaction, which is again expressed in string frame<sup>1</sup>.

The dilaton-dependent functions  $Z_{\frac{3}{2}}^{(0,0)}$  and  $Z_{\frac{5}{2}}^{(0,0)}$  in (1.1) and (1.2) are non-holomor-

---

<sup>1</sup>This symbolic notation indicates a term in which there are four (covariant) derivatives and four factors of the Riemann curvature. The precise pattern of index contractions will be specified by the form of the amplitudes to be calculated later.

phic Eisenstein (or Epstein) series that are special cases of the series

$$Z_s^{(w,w')} = \sum_{(m,n) \neq (0,0)} \frac{\Omega_2^s}{(m+n\Omega)^{s+w}(m+n\bar{\Omega})^{s+w'}}. \quad (1.3)$$

The modular weights  $w$  and  $w'$  are generally non-zero although they vanish in the case of interactions  $D^{4s-6}\mathcal{R}^4$  terms (with  $s = 3/2, 5/2, \dots$ ). More generally, interactions have  $w = -w' = q/2$  where  $q$  denotes the  $U(1)$  R-symmetry charge of the interaction under consideration. For example, there is an interaction of the form  $\int d^{10}x \sqrt{-g} e^{-\phi/2} Z_{3/2}^{(12,-12)} \lambda^{16}$  (where the dilatino  $\lambda$  transforms with weights  $(-3/4, 3/4)$ ). The series  $Z_s^{(0,0)}$  is an eigenfunction of the Laplace operator on the fundamental domain of  $SL(2, \mathbf{Z})$  with eigenvalue  $s(s-1)$ ,

$$\Delta_\Omega Z_s^{(0,0)} \equiv 4\Omega_2^2 \partial_\Omega \partial_{\bar{\Omega}} Z_s^{(0,0)} = s(s-1) Z_s^{(0,0)}. \quad (1.4)$$

It was shown in [6] (in the case of the  $\mathcal{R}^4$  interaction, which is the  $s = 3/2$  case) that this equation is a consequence of supersymmetry. The series with non-zero  $w$  and  $w'$  is similarly an eigenfunction of the Laplace operator with an  $(w, w')$ -dependent eigenvalue.

In the cases of relevance to this paper we always have  $(w, w') = (0, 0)$ , so we will drop the superscripts from hereon. For general values of  $s$   $Z_s$  has the large- $\Omega_2$  (weak coupling) expansion

$$Z_s(\Omega, \bar{\Omega}) = 2\zeta(2s)\Omega_2^s + 2\sqrt{\pi}\Omega_2^{1-s} \frac{\Gamma(s-\frac{1}{2})\zeta(2s-1)}{\Gamma(s)} + \frac{2\pi^s}{\Gamma(s)} \sum_{k \neq 0} \mu(k, s) e^{-2\pi(|k|\Omega_2 - ik\Omega_1)} |k|^{s-1} \left( 1 + \frac{s(s-1)}{4\pi|k|\Omega_2} + \dots \right), \quad (1.5)$$

where the last term comes from the asymptotic expansion of a modified Bessel function and  $\mu(k, s) = \sum_{d|k} 1/d^{2s-1}$ , as reviewed in appendix A. This expression contains precisely two power behaved terms proportional to  $\Omega_2^s$  and  $\Omega_2^{1-s}$ , which should be identified with tree-level and  $(s-1/2)$ -loop term in the IIB string perturbation expansion of the four graviton amplitude. In addition, there is an infinite sequence of  $D$ -instanton terms in  $Z_s$ , which have a characteristic phase of the form  $e^{2\pi ik\Omega}$ , where  $k$  is the instanton number.

Thus, with  $s = 3/2$  (the  $\mathcal{R}^4$  term) there are tree-level and one-loop terms, as well as the infinite series of  $D$ -instanton contributions. The absence of perturbative contributions to  $\mathcal{R}^4$  at two string loops has recently been confirmed by explicit evaluation of the two-loop string theory four-graviton amplitude [11, 12] and to all orders in [13]. In the  $s = 5/2$  case (the  $D^4\mathcal{R}^4$  term determined in [10]) the non-holomorphic Eisenstein series  $Z_{5/2}$  contains tree-level and two-loop perturbative string theory contributions, as well as a sequence of  $D$ -instantons. This agrees with the absence of a one-loop contribution [14] and predicts that there should be no perturbative terms beyond two loops, which has yet to be explicitly verified by a string loop calculation. The expression also predicts the value of the two loop contribution to  $D^4\mathcal{R}^4$  in type II string theory, which has recently been confirmed by calculations of four-graviton scattering in [15, 11, 16, 17] (see also [18, 19]).

New features are expected to arise at the next order in the low energy expansion. This is already clear from the form of the known tree-level contributions to higher derivative interactions that come from the  $\alpha' = l_s^2$  expansion of the tree-level four-graviton scattering

amplitude summarized in appendix A and is proportional to

$$\hat{K}^4 \frac{1}{l_s^8 stu} \exp \left( \sum_{n=1}^{\infty} \frac{2\zeta(2n+1)}{2n+1} \frac{l_s^{4n+2}}{4^{2n+1}} (s^{2n+1} + t^{2n+1} + u^{2n+1}) \right), \quad (1.6)$$

where  $\hat{K}$  is the linearized Weyl curvature and  $s + t + u = 0$ . At low orders the coefficients are proportional to  $\zeta$  functions that come from the exponent in (1.6):  $\zeta(3)$  in the case of the  $l_s^{-2} \mathcal{R}^4$  interaction and  $\zeta(5)$  in the case of  $l_s^2 D^4 \mathcal{R}^4$ . The nonperturbative extensions of these tree-level expressions are given by  $Z_{3/2}$  and  $Z_{5/2}$ , respectively. However, the next term in the expansion arises from the square of the exponent – this is the term proportional to  $\zeta(3)^2 l_s^4 D^6 \mathcal{R}^4$  with a coefficient that is the square of the  $\mathcal{R}^4$  coefficient. The challenge is to determine its nonperturbative extension. One might simply guess [20] that it is proportional to  $Z_{3/2}^2$ , which contains the correct tree-level term proportional to  $\zeta(3)^2$ , but this is ruled out since it makes an incorrect prediction for the one-loop contribution to  $D^6 \mathcal{R}^4$  [14]. The correct expression turns out to be much more subtle as we will see.

The objective of this paper is to extend the analysis of the dilaton dependence of higher derivative interactions to the  $D^6 \mathcal{R}^4$  interaction. This has the form (in string frame)

$$l_s^4 \int d^{10}x \sqrt{-g} e^\phi \mathcal{E}_{(\frac{3}{2}, \frac{3}{2})} D^6 \mathcal{R}^4, \quad (1.7)$$

where the function  $\mathcal{E}_{(3/2, 3/2)}(\Omega, \bar{\Omega})$  is a new  $(0, 0)$  modular form that depends on the complex coupling,  $\Omega$  (and the factor  $\Omega_2 = e^\phi$  disappears in Einstein frame). We will see that the function  $\mathcal{E}_{(3/2, 3/2)}$  satisfies a Laplace equation on moduli space with a source term,

$$\Delta_\Omega \mathcal{E}_{(\frac{3}{2}, \frac{3}{2})} = 12 \mathcal{E}_{(\frac{3}{2}, \frac{3}{2})} - 6 Z_{\frac{3}{2}} Z_{\frac{3}{2}}, \quad (1.8)$$

and determine its solution. These results will be obtained by expanding the two-loop supergravity amplitude compactified on  $\mathcal{T}^2$ , which was considered in [10], to first nontrivial order in the external momenta.

The coupling constant dependence of the function  $\mathcal{E}_{(3/2, 3/2)}$  encodes perturbative string tree-level, one-loop, two-loop effects and three-loop effects (proportional to  $\Omega_2^3$ ,  $\Omega_2$ ,  $\Omega_2^{-1}$  and  $\Omega_2^{-3}$ , respectively), together with an infinite number of  $D$ -instanton and double  $D$ -instanton effects. There are no other perturbative terms. The  $D$ -instanton terms are absent in the IIA theory, which can be obtained by compactification on a circle.<sup>2</sup>

The layout of the paper is as follows. In section 2 we will review the two-loop calculation of [10], where the  $D^4 \mathcal{R}^4$  term in the effective action were obtained by considering the low energy expansion of the two-loop contribution to eleven-dimensional supergravity compactified on  $\mathcal{T}^2$ . This is greatly facilitated by the observation in [1] that the two-loop amplitude has a simple expression as a kinematic factor multiplying a subset of the two-loop amplitudes of  $\varphi^3$  scalar field theory. The kinematic factor is simply the linearized approximation to  $D^4 \mathcal{R}^4$  so that in [10] we simply set the external momenta in these scalar

---

<sup>2</sup>The four-graviton amplitudes in the IIA and IIB theories are equal up to two loops — they probably differ at higher orders due to the contribution of odd-odd spin structures, which enter at three or more loops

field theory diagrams to zero in order to extract the effective  $D^4\mathcal{R}^4$  interaction. The integral representations for the loop diagrams compactified on a  $n$ -torus were expressed as integrals over three Schwinger parameters. These were particularly easy to evaluate after redefining the parameters so that the integrals were expressed as integrals over the complex structure  $\tau$  and volume  $V$  of a two-torus. Since the target space of interest is also a torus (with complex structure  $\Omega$  and volume  $\mathcal{V}$ ) the value of the integral was obtained by considering mappings of a torus into a torus.

Section 3 will be concerned with the extension of the analysis to the  $D^6\mathcal{R}^4$  interaction obtained by expanding two-loop supergravity four-graviton amplitude to quadratic order in the external momentum. Whereas in [10] we had to carefully regulate a divergent integral, the term of relevance to this paper is given by a finite integral. In section 4 we will consider compactification on a circle or radius  $R_{11}$ , which is related to the IIA string theory. In this case there is a single integer Kaluza-Klein charge corresponding to the discrete momentum in each loop. After performing the continuous momentum integrals the result is given as a sum over these integers. The expression is converted to a sum over windings ( $\hat{m}$ ,  $\hat{n}$ ) of the loops around the compact dimension, which isolates the divergence in the zero winding sector ( $\hat{m} = \hat{n} = 0$ ). The sum over non-zero windings gives a finite expression that correctly reproduces the known string tree-level coefficient proportional to  $\zeta(3)^2/R_{11}^6$ . As in the earlier cases [3, 10], the perturbative loop corrections of the IIA string theory are given by divergent expressions that are regulated by a cutoff in a manner that can be uniquely determined by relating them to the type IIB theory. This is obtained by compactification on  $\mathcal{T}^2$ , which is considered in section 5. After performing the integration over the two nine-dimensional continuous loop momenta the two-loop supergravity amplitude contribution to  $D^6\mathcal{R}^4$  will be expressed as an integral over three Schwinger parameters and a sum over the four winding numbers ( $(\hat{m}_I, \hat{n}_I)$  with  $I = 1, 2$ ) that correspond to windings of either loop around either direction on the toroidal target space. The terms we need to keep in the limit that gives the ten-dimensional type IIB theory are those that survive when  $\mathcal{V} \rightarrow 0$  – this is the limit in which type IIB string theory should be recovered. These terms, which are proportional to  $\mathcal{V}^{-3}$ , are given by finite integrals and unlike the terms discussed in [10] they do not need to be regularized.

In section 5.1 we will use an iterative procedure to evaluate these integrals, thereby leading to an expression for the dilaton-dependent coefficient,  $\mathcal{E}_{(3/2,3/2)}$ , contained in (1.7). This is given as a sum of two terms,  $\mathcal{E}_{(3/2,3/2)} = S + R$ , where  $S$  is an infinite series and  $R$  is an important remainder.

In section 5.2 we will show that  $\mathcal{E}_{(3/2,3/2)}$  has to satisfy the inhomogeneous Laplace equation (1.8) on the fundamental domain of on the fundamental domain of  $Sl(2, \mathbf{Z})$  acting on  $\Omega$ . We will argue that the general structure of this equation would be determined by a careful consideration of the conditions for IIB supersymmetry although we have not pursued this. The series  $S$  and the remainder  $R$  do not separately satisfy the Laplace equation (1.8), but the sum does. In section 5.3 we will analyze properties of  $\mathcal{E}_{(3/2,3/2)}$  and calculate the coefficients of the perturbative terms. Extracting these directly from the solution is complicated but we can bypass this by determining these coefficients directly from properties of the Laplace equation. In particular, we will obtain the values of the

coefficients of the terms proportional to  $\Omega_2^3$ ,  $\Omega_2$ ,  $\Omega_2^{-1}$ . The tree-level and one-loop terms agree with those already known from string perturbation theory and the value of the two-loop contribution is a new prediction since it has not yet been extracted directly from string perturbation theory. The evaluation of the three-loop contribution proportional to  $\Omega_2^{-3}$  is more subtle since it satisfies the homogeneous Laplace equation. In section 5.4 we will determine the value of its coefficient using modular properties of the Laplace equation and the fact that the  $\mathcal{E}_{(3/2,3/2)}$  is no more singular than  $\Omega_2^3$ . Strikingly, the value of the three-loop coefficient agrees with that of the three-loop contribution to  $D^6 R^4$  in the type IIA theory that was contained in [10] (see also [21]). No other perturbative contributions arise beyond the three-loop term.

An important feature of the two-loop and higher-loop terms in eleven-dimensional supergravity is that they have overall kinematic factors of the form  $D^4 \mathcal{R}^4$ , so that they do not give extra contributions to the one-loop  $\mathcal{R}^4$  term [1]. However, the structure of supergravity Feynman diagrams is not sufficiently well understood to know if diagrams with three or more loops will contribute to a renormalisation of the  $l_s^2 D^4 \mathcal{R}^4$  and  $l_s^4 D^6 \mathcal{R}^4$  interactions. The results of this paper indicate that these interactions are completely accounted for by the two-loop contributions and should therefore not receive higher-order corrections. This will be further discussed in section 6. We will give a dimensional argument that indicates that higher loop contributions to eleven-dimensional supergravity cannot contribute to these interactions. Furthermore, the general structure of the three-loop diagrams will be used to constrain the form of the dilaton dependence of the  $l_s^6 D^8 \mathcal{R}^4$  and  $l_s^8 D^{10} \mathcal{R}^4$  interactions. Other comments concerning the systematics of higher order terms will also be made in section 6.

We end in section 7 with a summary that includes the evaluation of the eleven-dimensional limit of the  $l_s^4 D^6 \mathcal{R}^4$  interaction. This interaction, together with others of the same dimension, are the first nontrivial corrections to the eleven-dimensional M-theory effective action after  $l_s^{-2} \mathcal{R}^4$  (and other terms of the same dimension) since the  $l_s^2 D^4 \mathcal{R}^4$  interaction vanishes in the eleven-dimensional limit.

## 2. Review of two-loop supergravity and the $D^4 \mathcal{R}^4$ interaction

Following [1] the two-loop four-graviton scattering amplitude in eleven-dimensional quantum supergravity has a very simple structure that can be expressed entirely in terms of a few scalar field theory diagrams.

The two-loop four-graviton amplitude,<sup>3</sup>  $A_4^{(2)}(S, T, U)$ , is given in terms of the sum of particular diagrams of  $\varphi^3$  scalar field theory illustrated in figure 1. These are the planar diagram,  $I^P(S, T)$ , and the non-planar diagram,  $I^{NP}(S, T)$ , together with the other diagrams obtained by permuting the external particles. The complete expression for the amplitude is (with same conventions as in [1])

$$A_4^{(2)} = i \frac{\kappa_{11}^6}{(2\pi)^{22}} \hat{K} \left[ S^2 I^{(S)} + T^2 I^{(T)} + U^2 I^{(U)} \right]$$

---

<sup>3</sup>Capital letters,  $S$ ,  $T$  and  $U$  denote Mandelstam invariants of the eleven-dimensional theory whereas lower case letters  $s$ ,  $t$  and  $u$  denote Mandelstam invariants in the IIB string theory frame.

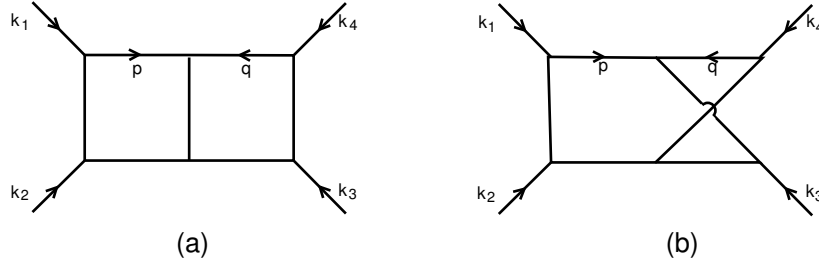

**Figure 1:** The ‘ $S$ -channel’ scalar field theory diagrams that contribute to the two-loop four-graviton amplitude of eleven-dimensional supergravity. (a) The  $(S, T)$  planar diagram,  $I^P(S, T)$ ; (b) The  $(S, T)$  non-planar diagram,  $I^{NP}(S, T)$ .

$$= i \frac{\kappa_{11}^6}{(2\pi)^{22}} \hat{K} [S^2 (I^P(S, T) + I^P(S, U) + I^{NP}(S, T) + I^{NP}(S, U)) + perms.], \quad (2.1)$$

where  $\hat{K}$  is the kinematical factor given by the linearization of the  $\mathcal{R}^4$  term, and  $perms$  signifies the sum of terms with permutations of  $S, T$  and  $U$  and

$$I^{(S)}(S, T, U) = \frac{1}{2} (I^P(S, T) + I^P(S, U) + I^{NP}(S, T) + I^{NP}(S, U)), \quad (2.2)$$

with analogous expressions for  $I^{(T)}$  and  $I^{(U)}$ . The expression (2.1) has an overall factor of  $\mathcal{R}^4$  together with four powers of the momentum multiplying the loop integrals which means that these diagrams are much less divergent than they would naively appear. The loop integrals are given by

$$I^P(S, T) = \int d^{11}p d^{11}q \frac{1}{p^2(p-k_1)^2(p-k_1-k_2)^2(p+q)^2q^2(q-k_3-k_4)^2(q-k_4)^2} \quad (2.3)$$

and

$$I^{NP}(S, T) = \int d^{11}p d^{11}q \frac{1}{p^2(p-k_1)^2(p+q)^2(p-k_1-k_2)^2q^2(p+q+k_3)^2(q-k_4)^2} \quad (2.4)$$

which have ultraviolet divergences of order  $(momentum)^8$  that will need to be regularized.

In addition to these two-loop diagrams there is a contribution to the amplitude from the one-loop triangle diagram in which there is one insertion of the linearized one-loop counterterm. Together with the two-loop counterterm, this gives additional contributions to the amplitude that are not relevant for the purposes of this paper.

## 2.1 Evaluation of the two-loop amplitude on $\mathcal{T}^n$

Still following [10] we shall now consider the leading contribution to the derivative expansion arising from these two-loop diagrams when compactified on  $\mathcal{T}^2$ , which contributes to the  $D^4\mathcal{R}^4$  interaction. For convenience our considerations will be restricted to situations in which the polarization tensors and momenta of the gravitons are in directions transverse to torus and covariantise the final result. We will first be slightly more general and consider



the case of compactification on an  $n$ -torus  $\mathcal{T}^n$  with metric  $G_{IJ}$  and volume  $\mathcal{V}_n$ , in which case the planar diagram with external momenta  $k_r$   $r = 1, \dots, 4$  is given by the expression,

$$I^P(S, T) = \frac{1}{l_{11}^{2n} \mathcal{V}_n^2} \sum_{(m_I, n_I)} \int d^{11-n} p d^{11-n} q \times \\ \times \int \prod_{r=1}^7 d\sigma_r e^{-[G^{IJ}(\sigma m_I m_J + \lambda n_I n_J + \rho(m+n)_I(m+n)_J) + \sum_{r=1}^7 K_r \sigma_r]}, \quad (2.5)$$

where  $I, J = 1, 2$  label the directions in  $\mathcal{T}^n$ . The vector  $K_r$  is defined by

$$K_r = (p, p - k_1, p - k_1 - k_2, q, q - k_4, q - k_3 - k_4, p + q), \quad (2.6)$$

and

$$\sigma = \sigma_1 + \sigma_2 + \sigma_3, \quad \lambda = \sigma_4 + \sigma_5 + \sigma_6, \quad \rho = \sigma_7. \quad (2.7)$$

The non-planar diagram is given by

$$I^{NP}(S, T) = \frac{1}{l_{11}^{2n} \mathcal{V}_n^2} \sum_{(m_I, n_I)} \int d^{11-n} p d^{11-n} q \times \\ \times \int \prod_{r=1}^7 d\sigma_r e^{-[G^{IJ}(\sigma m_I m_J + \lambda n_I n_J + \rho(m+n)_I(m+n)_J) + \sum_{r=1}^7 K'_r \sigma_r]}, \quad (2.8)$$

where

$$K'_r = (q, q - k_4, p, p - k_1, p - k_1 - k_2, p + q, p + q + k_3), \quad (2.9)$$

and

$$\sigma = \sigma_1 + \sigma_2, \quad \lambda = \sigma_3 + \sigma_4 + \sigma_5, \quad \rho = \sigma_6 + \sigma_7. \quad (2.10)$$

The loop momentum integrals are performed in the standard manner by completing the squares in the exponent followed by gaussian integration. We are envisioning introducing some sort of cutoff at large momenta by imposing a lower limit to the range of integration of the Schwinger parameters. The precise details will be clarified following suitable changes of variables below. Ignoring these for now, the resultant expressions for the planar and non-planar loops are,

$$I^P(S, T) = \frac{\pi^{11-n}}{l_{11}^{2n} \mathcal{V}_n^2} \sum_{(m_I, n_I)} \int_0^\infty d\sigma d\lambda d\rho \frac{\sigma^2 \lambda^2}{\Delta^{\frac{11-n}{2}}} e^{-G^{IJ}(\sigma m_I m_J + \lambda n_I n_J + \rho(m+n)_I(m+n)_J)} \times \\ \times \int_0^1 dv_2 dw_2 \int_0^{v_2} dv_1 \times \\ \times \int_0^{w_2} dw_1 e^{T \frac{\sigma \lambda \rho}{\Delta} (v_2 - v_1)(w_2 - w_1) + S[\frac{\sigma \lambda \rho}{\Delta} (v_1 - w_1)(v_2 - w_2) + \sigma v_1(1 - v_2) + \lambda w_1(1 - w_2)]}, \quad (2.11)$$

and

$$I^{NP}(S, T) = \frac{\pi^{11-n}}{l_{11}^{2n} \mathcal{V}_n^2} \sum_{(m_I, n_I)} \times \\ \times \int_0^\infty d\sigma d\lambda d\rho \frac{2\sigma \lambda^2 \rho}{\Delta^{\frac{11-n}{2}}} e^{-G^{IJ}(\sigma m_I m_J + \lambda n_I n_J + \rho(m+n)_I(m+n)_J)} \int_0^1 du_1 dv_1 dw_2 \times \\ \times \int_0^{w_2} dw_1 e^{T \frac{\sigma \lambda \rho}{\Delta} (w_2 - w_1)(u_1 - v_1) + S[\frac{(\sigma + \rho)\lambda^2}{\Delta} w_1(1 - w_2) + \frac{\sigma \lambda \rho}{\Delta} (w_1(1 - u_1) + v_1(u_1 - w_2))]} \quad (2.12)$$

(where the variables  $u_1, v_1, v_2, w_1$  and  $w_2$  are rescalings of  $\sigma_i$ ). These expressions can be expanded in powers of  $S, T$  and  $U$  in order to determine their contributions to higher derivatives acting on  $S^2 \mathcal{R}^4$ .

The leading term in the low energy expansion (of order  $S^2 \mathcal{R}^4$ ) is obtained by setting the external momenta to zero so that  $S, T$  and  $U$  are set equal to zero in  $I^P$  and  $I^{NP}$ . After summing these two zero-momentum contributions followed by a sum over all the diagrams required by Bose symmetrization the result is

$$I^P(0) + I^{NP}(0) = \frac{\pi^{11-n}}{3 l_{11}^{2n} \mathcal{V}_n^2} \sum_{(m_I, n_I)} \int_0^\infty d\sigma d\lambda d\rho \frac{1}{\Delta^{\frac{7-n}{2}}} e^{-G^{IJ}(\sigma m_I m_J + \lambda n_I n_J + \rho(m+n)_I(m+n)_J)}, \quad (2.13)$$

which is symmetric in the parameters  $\sigma, \lambda$  and  $\rho$ . The integration in (2.13) is divergent for every value of  $m^I, n^I$  when  $\Delta \sim 0$ , which requires at least two of the parameters  $\lambda, \rho, \sigma$  to approach zero simultaneously. The sums contribute additional divergences, which makes this representation of the amplitude rather awkward to analyze.

As in the case of the one-loop amplitude [3] it is convenient to analyze the divergences after performing a Poisson resummation over the Kaluza–Klein modes,  $m_I, n_I$ , which transforms them into winding numbers,  $\hat{m}_I, \hat{n}_I$ , and also to redefine the Schwinger parameters by,

$$\hat{\sigma} = \frac{\sigma}{\Delta}, \quad \hat{\lambda} = \frac{\lambda}{\Delta}, \quad \hat{\rho} = \frac{\rho}{\Delta}, \quad (2.14)$$

where

$$\Delta = \sigma\lambda + \sigma\rho + \lambda\rho = \hat{\Delta}^{-1} = (\hat{\sigma}\hat{\lambda} + \hat{\sigma}\hat{\rho} + \hat{\lambda}\hat{\rho})^{-1}. \quad (2.15)$$

The amplitude (2.13) becomes (after a rescaling,  $\hat{\sigma} \rightarrow \hat{\sigma}/\pi$ )

$$I^{P+NP}(0) = \frac{\pi^7}{3} \sum_{(m_I, n_I)} \int_0^\infty d\hat{\sigma} d\hat{\lambda} d\hat{\rho} \hat{\Delta}^{1/2} e^{-\pi E_w}, \quad (2.16)$$

where the exponent is defined by

$$E_w(\hat{\sigma}, \hat{\lambda}, \hat{\rho}) = G_{IJ} \left( \hat{\lambda} \hat{m}_I \hat{m}_J + \hat{\sigma} \hat{n}_I \hat{n}_J + \hat{\rho} (\hat{m} + \hat{n})_I (\hat{m} + \hat{n})_J \right), \quad (2.17)$$

and is a function of the winding numbers. The parameters  $\hat{\sigma}, \hat{\lambda}$  and  $\hat{\rho}$  will be referred to as ‘winding parameters’. The classification of the divergences is simplified in the winding number basis. For example, the sector in which all the winding numbers vanish diverges at the end-point where all of the winding parameters reach their upper limits. This term is independent of the metric  $G_{IJ}$  and is the primitive two-loop divergence. There are many sectors that contribute to subleading divergences. The simplest examples are those sectors in which the winding numbers conjugate to a particular winding parameter vanish. In those cases the integral diverges at the endpoint where that parameter reaches its upper limit, which gives a sub-leading divergence. For example, the  $\hat{\sigma}$  integral diverges in the  $\hat{n}_I = 0$  sector and behaves as  $\Lambda^3$  if  $\hat{\sigma}$  is cut off at the value  $\Lambda^2$  (that was introduced in order to cut off the one-loop winding parameter). Sectors with less than  $n$  vanishing winding

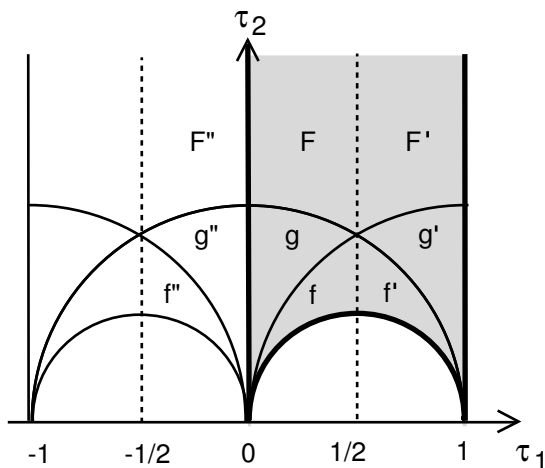

**Figure 2:** The domain of integration over the parameters  $\tau_1$  and  $\tau_2$ , bounded by the thick line, is the fundamental domain of  $\Gamma_0(2)$ .

numbers give non-divergent contributions which are independent of any cutoff. This will be the situation for the interaction considered in the main part of this paper.

A more complete analysis of the integral is greatly facilitated by the observation that the integrand possesses a secret  $SL(2, \mathbf{Z})$  symmetry that is not at all apparent in the  $\hat{\lambda}, \hat{\rho}, \hat{\sigma}$  parameterization. This symmetry is made manifest by redefining the integration variables in (2.16) so that the parameters,  $\hat{\rho}, \hat{\lambda}$  and  $\hat{\sigma}$ , are replaced by the dimensionless volume,  $V$ , and complex structure,  $\tau = \tau_1 + i\tau_2$ , of a two-torus,  $\hat{\mathcal{T}}^2$ , defined by

$$\tau_1 = \frac{\hat{\rho}}{\hat{\rho} + \hat{\lambda}}, \quad \tau_2 = \frac{\sqrt{\hat{\Delta}}}{\hat{\rho} + \hat{\lambda}}, \quad V = l_{11}^2 \sqrt{\hat{\Delta}}. \quad (2.18)$$

The jacobian for the change of variables from  $(\hat{\sigma}, \hat{\lambda}, \hat{\rho})$  to  $(V, \tau)$  is

$$d\hat{\lambda}d\hat{\sigma}d\hat{\rho} = 2l_{11}^{-6} dV V^2 \frac{d^2\tau}{\tau_2^2}, \quad (2.19)$$

where  $d^2\tau = d\tau_1 d\tau_2$ . It is easy to see how the domain of integration of the Schwinger variables translates into the integration domain for  $V$  and  $\tau$ . The volume  $V$  is integrated over  $[0, \infty]$  and the domain of integration of  $\tau$  is the fundamental domain of the  $\Gamma_0(2)$  sub-group of  $SL(2, \mathbf{Z})$  (the shaded region in figure 2),

$$\mathcal{F}_{\Gamma_0(2)} = \left\{ 0 \leq \tau_1 \leq 1, \tau_2^2 + \left(\tau_1 - \frac{1}{2}\right)^2 \geq \frac{1}{4} \right\}, \quad (2.20)$$

which consists of the sectors  $F \oplus F' \oplus g \oplus g' \oplus f \oplus f'$ . As is clear from the figure 2 this domain covers precisely three copies of  $\mathcal{F} = F \oplus F''$ , the fundamental domain of  $SL(2, \mathbf{Z})$ . More concretely, in terms of the conventional generators of  $SL(2, \mathbf{Z})$ :<sup>4</sup> region  $g$  is mapped

<sup>4</sup>Which are the translation  $T : \tau \rightarrow \tau + 1$  and the inversion  $S : \tau \rightarrow -1/\tau$ .

into  $F''$  by  $S$ ; region  $g'$  is mapped into  $F$  by  $ST^{-1}$ ; region  $f$  is mapped into  $F$  by  $TS$ ; region  $f'$  is mapped into  $F''$  by  $T^{-1}ST^{-1}$ ; region  $F'$  is mapped into  $F''$  by  $T^{-1}$ . Substituting the change of variables (2.18) into the integral (2.16) gives

$$I^{P+NP}(0) = \frac{2\pi^7}{l_{11}^8} \sum_{(m_I, n_I)} \int_0^\infty dV V^3 \int_{\mathcal{F}_{\Gamma_0(2)}} \frac{d^2\tau}{\tau_2^2} e^{-\pi \frac{V G_{IJ}}{l_{11}^2 \tau_2} [(\hat{m} + \tau \hat{n})^I (\hat{m} + \bar{\tau} \hat{n})^J]} . \quad (2.21)$$

When the eleven-dimensional two-loop amplitude is compactified on a two-torus ( $n = 2$ ) of volume  $\mathcal{V}$  and complex structure  $\Omega$  the exponential factor (2.17) can be written as

$$E = \frac{\mathcal{V} V}{\Omega_2 \tau_2} |(1 \ \Omega) M(\tau \ 1)|^2 - 2\mathcal{V} V \det M , \quad (2.22)$$

where the metric on the two-torus is

$$G_{IJ} \hat{m}_I \hat{m}_J = l_{11}^2 \mathcal{V} \frac{|\hat{m}_1 + \hat{m}_2 \Omega|^2}{\Omega_2} , \quad (2.23)$$

and we have defined a  $2 \times 2$  matrix  $M$

$$M = \begin{pmatrix} \hat{m}_1 & \hat{n}_1 \\ \hat{m}_2 & \hat{n}_2 \end{pmatrix} . \quad (2.24)$$

In this case the expression (2.21) becomes

$$I_{D^4 R^4} = \frac{2\pi^7}{l_{11}^8} \sum_{(\hat{m}_I, \hat{n}_I)} \int_0^\infty dV V^3 \int_{\mathcal{F}} \frac{d^2\tau}{\tau_2^2} e^{-\pi E} \quad (2.25)$$

This integral, which resembles the integral that arises in evaluating a one-loop string amplitude in a toroidally compactified space, was analyzed in detail in [10]. In particular, it was shown that the coefficient of the  $D^4 \mathcal{R}^4$  interaction is determined by a one-loop sub-divergence, which diverges like  $\Lambda^3$ . This integral was regulated by introducing the one-loop counterterm that had been determined previously from the analysis of the one-loop  $\mathcal{R}^4$  term. As a result the coefficient of the  $D^4 \mathcal{R}^4$  term was found to be proportional to  $Z_{5/2}$ , which is the  $s = 5/2$  case of the non-holomorphic Eisenstein series (1.3).

The tree-level part of  $Z_{5/2}$  is proportional to  $\zeta(5) \Omega_2^{5/2}$ , and the overall coefficient that emerged from the analysis in [10] is precisely the one expected from the tree-level string four-graviton scattering amplitude. Furthermore, the fact that  $Z_{5/2}$  does not possess a  $\Omega_2^{1/2}$  term implies that there is no contribution to  $D^4 \mathcal{R}^4$  at one loop in string theory in ten dimensions<sup>5</sup> as was verified in [14]. The coefficient of the  $\Omega_2^{-3/2}$  piece of  $Z_{5/2}$  gave a prediction for the two-loop contribution to  $D^4 \mathcal{R}^6$  which has been verified by direct calculation in string perturbation theory at two-loop order in [15].

---

<sup>5</sup>This is an example of how a contribution vanishes only after integration over the string moduli (here the one-loop modulus  $\tau$ ). This kind of phenomenon is expected to be the origin of non-renormalisation theorems for higher-derivative terms at higher-loop order.

### 3. $D^6\mathcal{R}^4$ interaction from two-loop supergravity

We now turn to consider the next term in the expansion of the two-loop diagrams that contribute to  $A_4^{(2)}$  in (2.1). This involves expanding the integrals  $I^P(S, T)$ ,  $I^P(S, U)$ ,  $I^{NP}(S, T)$  and  $I^{NP}(S, U)$  ((2.12) and (2.13) and the corresponding expressions with  $T$  and  $U$  interchanged) to first order in the invariants  $S$ ,  $T$  and  $U$ . This will give  $(S^3 + T^3 + U^3)\mathcal{R}^4$ , which corresponds to the terms of the form  $D^6\mathcal{R}^4$  in the effective action,

$$S_{D^6R^4} = \frac{l_{11}^5}{96 \cdot (4\pi)^7} \int d^9x \sqrt{-G^{(9)}} \mathcal{V} h(\mathcal{V}, \Omega, \bar{\Omega}) D^6\mathcal{R}^4. \quad (3.1)$$

The function  $h(\mathcal{V}, \Omega)$  has an expansion in powers of  $\mathcal{V}$ , which has the form

$$h(\mathcal{V}, \Omega, \bar{\Omega}) = \frac{\pi^6}{4\mathcal{V}^3} \mathcal{E}_{(\frac{3}{2}, \frac{3}{2})}(\Omega, \bar{\Omega}) + \dots, \quad (3.2)$$

where  $\dots$  indicates terms with higher powers of  $\mathcal{V}$ , which are functions of the cutoff but are negligible in the  $\mathcal{V} \rightarrow 0$  limit. Using the dictionary in appendix B to those of type II string theory we can express the eleven-dimensional  $D^6\mathcal{R}^4$  action (3.1) in terms of the IIB string variables,

$$S_{D^6R^4}^{(IIB)} = l_s^5 \frac{\pi^6}{4 \cdot 96 \cdot (4\pi)^7} \int d^9x \sqrt{-g^B} r_B e^{\phi^B} h(\mathcal{V}, \Omega, \bar{\Omega}) \mathcal{V}^3 D^6R^4, \quad (3.3)$$

which has the finite  $\mathcal{V} \rightarrow 0$  limit given by (1.7),

$$S_{D^6R^4}^{(IIB)} = l_s^4 \frac{\pi^6}{4 \cdot 96 \cdot (4\pi)^7} \int d^{10}x \sqrt{-g^B} e^{\phi^B} \mathcal{E}_{(\frac{3}{2}, \frac{3}{2})}(\Omega, \bar{\Omega}) D^6R^4. \quad (3.4)$$

#### 3.1 Expansion of two-loop integrals

The result of expanding the sum of diagrams contributing to  $I^{(S)}$  in (2.2) to first order in the Mandelstam invariants is (after integrating over  $v_1, v_2, w_1, w_2$  and using  $S + T + U = 0$ ) denote

$$I^{(S)} = I^{P+NP}(0) + \frac{l_{11}^2}{12} S I' + \dots, \quad (3.5)$$

where

$$I' = \frac{\pi^{11-n}}{3\mathcal{V}_n^2} \sum_{(m_I, n_I)} \int_0^\infty d\sigma d\lambda d\rho \frac{(\lambda + \rho + \sigma)\Delta - 5\lambda\rho\sigma}{\Delta^{\frac{9-n}{2}}} e^{-G^{IJ}(\sigma m_I m_J + \lambda n_I n_J + \rho(m+n)_I(m+n)_J)}. \quad (3.6)$$

We now perform the Poisson resummations as before and transform the integration variables from Kaluza-Klein charges to winding numbers using (2.14). This results in

$$I' = \frac{\pi^8}{3} \sum_{(m_I, n_I)} \int_0^\infty d\hat{\sigma} d\hat{\lambda} d\hat{\rho} \frac{\hat{\lambda} + \hat{\rho} + \hat{\sigma} - 5\hat{\lambda}\hat{\rho}\hat{\sigma}\hat{\Delta}^{-1}}{\hat{\Delta}^{1/2}} e^{-\pi G_{IJ}(\hat{\sigma} \hat{m}_I \hat{m}_J + \hat{\lambda} \hat{n}_I \hat{n}_J + \hat{\rho}(\hat{m} + \hat{n})_I(\hat{m} + \hat{n})_J)}. \quad (3.7)$$

Now we make the further transformations to the torus variables  $\tau_1, \tau_2$  and  $V$ , defined by (2.18), which gives

$$I' = 2\pi^8 \sum_{(m_I, n_I)} \int_0^\infty dV V^2 \int_{\mathcal{F}_{\Gamma_0(2)}} \frac{d^2\tau}{\tau_2^2} \hat{A} e^{-\pi \frac{V G_{IJ}}{l_{11}^2 \tau_2} [(\hat{m} + \tau \hat{n})^I (\hat{m} + \tau \hat{n})^J]}, \quad (3.8)$$

where

$$\hat{A} = \frac{|\tau|^2 - \tau_1 + 1}{\tau_2} + 5 \frac{\tau_1(\tau_1 - 1)(|\tau|^2 - \tau_1)}{\tau_2^3}. \quad (3.9)$$

Although the function  $\hat{A}$  is not invariant under  $SL(2, \mathbf{Z})$  it has simple transformation properties. Under both the inversion  $S$  ( $\tau \rightarrow -1/\tau$ ) and under the translation  $T$  ( $\tau \rightarrow \tau + 1$ ), the function  $\hat{A}(\tau_1, \tau_2)$  transforms into  $\hat{A}(-\tau_1, \tau_2)$ . Using this fact it is easy to see how to map the regions  $g, g', f, f'$  and  $F'$  into the fundamental domain consisting of the regions  $F''$  and  $F$ . The result is that the integral (3.7) can be replaced by an integral over the fundamental domain of the form

$$I' = 2\pi^8 \sum_{(m_I, n_I)} \int_0^\infty dV V^2 \int_{\mathcal{F}} \frac{d^2\tau}{\tau_2^2} A e^{-\pi \frac{V G_{IJ}}{l_{11}^2 \tau_2} [(\hat{m} + \tau \hat{n})^I (\hat{m} + \tau \hat{n})^J]}, \quad (3.10)$$

where

$$A(\tau_1, \tau_2) = \frac{|\tau|^2 - |\tau_1| + 1}{\tau_2} + 5 \frac{(\tau_1^2 - |\tau_1|)(|\tau|^2 - |\tau_1|)}{\tau_2^3}. \quad (3.11)$$

It will prove important later that  $A$  satisfies the Laplace equation<sup>6</sup>

$$\Delta_\tau A = \tau_2^2 (\partial_{\tau_1}^2 + \partial_{\tau_2}^2) A = 12 A - 12 \tau_2 \delta(\tau_1) \quad (3.12)$$

#### 4. Compactification on a circle

A simple dimensional argument shows that compactifying the four-graviton supergravity amplitude on a circle of radius  $R_{11}$  (i.e., the case  $n = 1$  in (3.6)) will give a finite term of order  $1/R_{11}^6$  which is to be identified with the IIA superstring tree amplitude. In this section we will find the coefficient of this term and see that it is precisely the value expected from the direct calculation of the tree-level string amplitude.

In this case (3.10) is given by

$$I' = \frac{2\pi^8}{l_{11}^6} \sum_{(\hat{m}, \hat{n})'} \int_0^\infty dV V^2 \int_{\mathcal{F}} \frac{d^2\tau}{\tau_2^2} A e^{-\pi E}, \quad (4.1)$$

where

$$E = \frac{V R_{11}^2}{l_{11}^2} \frac{|\hat{m} + \tau \hat{n}|^2}{\tau_2}, \quad (4.2)$$

and  $(\hat{m}, \hat{n})'$  indicates that the value  $(0, 0)$  is omitted from the sum.

---

<sup>6</sup>As explained in Appendix C, this identity has to be understood as a weak equality integrated over the fundamental domain  $\mathcal{F}$ .

It is easy to see by changing the integration variable  $V$  to  $VR_{11}^2$  that  $I' = a/R_{11}^6$ , where  $a$  is independent of  $R_{11}$ . From this it follows that

$$\left(v^2 \frac{\partial^2}{\partial v^2} + 2v \frac{\partial}{\partial v}\right) I' = 6I', \quad (4.3)$$

where  $v = R_{11}^2$ . On the other hand, if we do not redefine the integration variable we have

$$\begin{aligned} \left(v^2 \frac{\partial^2}{\partial v^2} + 2v \frac{\partial}{\partial v}\right) I' &= \frac{2\pi^8}{l_{11}^6} \sum_{(\hat{m}, \hat{n})} \int_0^\infty dV V^2 \int_{\mathcal{F}} \frac{d^2\tau}{\tau_2^2} A(\pi^2 E^2 - 2\pi E) e^{-\pi E} \\ &= \frac{2\pi^8}{l_{11}^6} \sum_{(\hat{m}, \hat{n})} \int_0^\infty dV V^2 \int_{\mathcal{F}} \frac{d^2\tau}{\tau_2^2} A \Delta_\tau e^{-\pi E}, \end{aligned} \quad (4.4)$$

where we have used the fact that

$$\Delta_\tau e^{-\pi E} = (\pi^2 E^2 - 2\pi E) e^{-\pi E}, \quad (4.5)$$

as can be seen by simple manipulations. Integrating (4.4) by parts twice gives

$$\left(v^2 \frac{\partial^2}{\partial v^2} + 2v \frac{\partial}{\partial v}\right) I' = \frac{2\pi^8}{l_{11}^6} \sum_{(\hat{m}, \hat{n})} \int_0^\infty dV V^2 \int_{\mathcal{F}} \frac{d^2\tau}{\tau_2^2} \Delta_\tau A e^{-\pi E}, \quad (4.6)$$

where the surface terms vanish so long as  $\hat{m}$  and  $\hat{n}$  are both non-zero. Now we can use (3.12) and (4.3) to write this as

$$6I' = 12I' - 12 \frac{2\pi^8}{l_{11}^6} \sum_{(\hat{m}, \hat{n})'} \int_0^\infty dV V^2 \int_1^\infty \frac{d\tau_2}{\tau_2} \delta(\tau_1) e^{-\pi E}. \quad (4.7)$$

After making use of the symmetry of the integrand under  $\tau_2 \rightarrow 1/\tau_2$   $I'$  can be written as

$$I' = \frac{2\pi^8}{l_{11}^6} \int_0^\infty V^2 dV \int_0^\infty \frac{d\tau_2}{\tau_2} e^{-\pi \frac{VR_{11}^2}{l_{11}^2 \tau_2} (\hat{m}^2 + \tau_2^2 \hat{n}^2)}. \quad (4.8)$$

We now change variables to  $x$  and  $y$ , defined by

$$x = V\tau_2, \quad y = \frac{V}{\tau_2}, \quad (4.9)$$

so that  $I'$  can be written as

$$I' = \frac{\pi^8}{l_{11}^6} \int_0^\infty dx dy x^{1/2} y^{1/2} e^{-\pi \frac{R_{11}^2}{l_{11}^2} (\hat{m}^2 y + \hat{n}^2 x)} = \frac{\pi^6}{R_{11}^6} \zeta(3)^2. \quad (4.10)$$

To this order in the momentum expansion the contribution of the two-loop amplitude (2.1) on a circle is

$$A_4^{(2)} = \frac{i}{2} \frac{\kappa_{11}^6}{(2\pi)^2} \frac{\pi^6}{l_{11}^8} \hat{K} \left( \frac{\zeta(5)}{R_{11}^5} (S^2 + T^2 + U^2) + \frac{\zeta(3)^2}{6R_{11}^6} l_{11}^2 (S^3 + T^3 + U^3) \right), \quad (4.11)$$

where we have included the results of [10] for the  $\zeta(5) D^4 R^4$  term. The relative normalization of 1/6 between these terms agrees with the tree-level string amplitude given in the appendix A. Since we showed in [10] that the normalization of the  $\zeta(5) D^4 R^4$  term also agrees with those of the lower order terms in the series, we conclude that our two-loop calculation of the  $D^6 \mathcal{R}^4$  term also agrees.

## 5. Compactification on $\mathcal{T}^2$

As was seen in the case of the  $\mathcal{R}^4$  term obtained from one loop in eleven dimensional supergravity in [3], compactification on a circle cannot determine the correct regularization of divergent terms, which correspond to perturbative loop contributions to  $\mathcal{R}^4$  in the IIA string action. However, one can determine these by compactifying on a two-torus (the case  $n = 2$  in (3.6)) with volume  $\mathcal{V}$  and complex structure  $\Omega$ . The limit  $\mathcal{V} \rightarrow 0$  leads to a finite term in the IIB action that contains the full non-perturbative dependence on the complex dilaton. This contains specific tree-level and perturbative string loop contributions as well as an infinite series of  $D$ -instanton terms. This determines the regulated IIA one-loop contribution since it is known that the four-graviton amplitude in the IIA theory only receives perturbative contributions that are equal to those in the IIB theory, at least up to two loops. In this section we will evaluate the leading term in the  $\mathcal{V} \rightarrow 0$  limit of the  $\mathcal{T}^2$  compactification of the  $D^6\mathcal{R}^4$  interaction, which is the  $n = 2$  case of (3.6).

### 5.1 Evaluation of integral

We want to evaluate the integral (3.8) in the toroidal background defined by the metric (2.23). It will also prove useful to define a generalization of  $I'$ , labelled by an integer  $p \geq 1$  (where  $I_1 \equiv I'$  and the powers of  $l_{11}$  have been rescaled in  $V$ ),

$$I_p = 2\pi^8 \sum_{(\hat{m}_I, \hat{n}_I)'} (\det M)^{2p-2} \int_0^\infty dV V^{2p} \int_{\mathcal{F}} \frac{d^2\tau}{\tau_2^2} A e^{-\pi E} \quad (5.1)$$

(where  $(\hat{m}_I, \hat{n}_I)$  indicates that the values  $(\hat{m}_1, \hat{n}_2) = (0, 0)$  and  $(\hat{n}_1, \hat{n}_2) = (0, 0)$  are omitted from the sum). The fact that  $E$  is proportional to  $\mathcal{V}V$  implies that  $I_p$  has the form

$$I_p = 2\pi^8 \frac{\mathcal{I}_p}{\pi^{2p+1} \mathcal{V}^{2p+1}}, \quad (5.2)$$

from which it follows, on the one hand, that

$$\left( \mathcal{V}^2 \frac{\partial^2}{\partial \mathcal{V}^2} + 2\mathcal{V} \frac{\partial}{\partial \mathcal{V}} \right) I_p = 2p(2p+1) I_p \quad (5.3)$$

and, on the other hand, the partial sums,

$$I_p^{(\hat{m}_I, \hat{n}_I)} = \frac{\mathcal{I}_p^{(\hat{m}_I, \hat{n}_I)}}{\pi^{2p+1} \mathcal{V}^{2p+1}} = \int_0^\infty dV V^{2p} \int_{\mathcal{F}} \frac{d^2\tau}{\tau_2^2} A e^{-\pi E}, \quad (5.4)$$

satisfy

$$\begin{aligned} \left( \mathcal{V}^2 \frac{\partial^2}{\partial \mathcal{V}^2} + 2\mathcal{V} \frac{\partial}{\partial \mathcal{V}} \right) I_p^{(\hat{m}_I, \hat{n}_I)} &= \int_0^\infty dV V^{2p} \int_{\mathcal{F}} \frac{d^2\tau}{\tau_2^2} A (\pi^2 E^2 - 2\pi E) e^{-\pi E} \\ &= \int_0^\infty dV V^{2p} \int_{\mathcal{F}} \frac{d^2\tau}{\tau_2^2} (A \Delta_\tau e^{-\pi E} + (2\pi \mathcal{V} \det M)^2 e^{-\pi E}). \end{aligned} \quad (5.5)$$



Integrating the last expression by parts twice and combining it with (5.3) gives

$$2p(2p+1)\mathcal{I}_p^{(\hat{m}_I, \hat{n}_I)} = \pi^{2p+1}\mathcal{V}^{2p+1} \int_0^\infty dV V^{2p} \int_{\mathcal{F}} \frac{d^2\tau}{\tau_2^2} (\Delta_\tau A) e^{-\pi E} + (2 \det M)^2 \mathcal{I}_{p+1}^{(\hat{m}_I, \hat{n}_I)} + S_p^{\tau_2=\infty}, \quad (5.6)$$

where we have used

$$\Delta_\tau e^{-\pi E} = (\pi^2 E^2 - 2\pi E - (2\pi\mathcal{V} \det M)^2) e^{-\pi E}, \quad (5.7)$$

and the fact that the surface terms vanish, apart from contributions from the boundary at  $\tau_2 = \infty$ , which are contained in the last term. The vanishing of the surface terms follows from the fact that  $A$  satisfies the boundary conditions,

$$\begin{aligned} A(\tau_1, \tau_2)|_{\tau_1=-\frac{1}{2}} &= A(\tau_1, \tau_2)|_{\tau_1=\frac{1}{2}}, & A(\tau_1, \tau_2)|_{|\tau|=1} &= A(-\tau_1, \tau_2)|_{|\tau|=1}, \\ \partial_{\tau_1} A(\tau_1, \tau_2)|_{\tau_1=\pm\frac{1}{2}} &= 0, & \partial_{|\tau|} A(\tau_1, \tau_2)|_{|\tau|=1} &= -\partial_{|\tau|} A(-\tau_1, \tau_2)|_{|\tau|=1}. \end{aligned} \quad (5.8)$$

The contribution from the boundary at  $\tau_2 = \infty$  is exponentially suppressed for terms with  $\det M \neq 0$ , but does contribute (and is divergent) for terms in which  $\det M = 0$  (i.e. for singular or degenerate orbits of  $SL(2, \mathbf{Z})$ .) Such terms need to be regulated as in [10]. However, they have a higher power of the volume  $\mathcal{V}$ , as follows from simple dimensional analysis, and are therefore suppressed in the IIB limit,  $\mathcal{V} \rightarrow 0$  that we are considering, so  $S_p^{\tau_2=\infty}$  will be ignored in the following.

Substituting  $\Delta_\tau A = 12A - 12\tau_2 \delta(\tau_1)$  in (5.6) gives

$$2p(2p+1)\mathcal{I}_p^{(\hat{m}_I, \hat{n}_I)} = 12\mathcal{I}_p^{(\hat{m}_I, \hat{n}_I)} + J_p^{(\hat{m}_I, \hat{n}_I)} + (2 \det M)^2 \mathcal{I}_{p+1}^{(\hat{m}_I, \hat{n}_I)}, \quad (5.9)$$

where

$$J_p^{(\hat{m}_I, \hat{n}_I)} = -6\pi^{2p+1}\mathcal{V}^{2p+1} \int_0^\infty dV V^{2p} \int_0^\infty \frac{d\tau_2}{\tau_2} e^{-\pi E} \Big|_{\tau_1=0}. \quad (5.10)$$

The symmetry of the integrand under  $\tau_2 \rightarrow 1/\tau_2$  has been used to extend the integration range of the  $\tau_2$  integral to the range  $0 \leq \tau_2 \leq \infty$ . Noting that

$$E|_{\tau_1=0} = \frac{V\mathcal{V}}{\Omega_2} \left[ \frac{|\hat{m}_1 + \hat{m}_2\Omega|^2}{\tau_2} + \tau_2 |\hat{n}_1 + \hat{n}_2\Omega|^2 \right], \quad (5.11)$$

and setting  $x = V\tau_2$  and  $y = V/\tau_2$  gives

$$\begin{aligned} J_p^{(\hat{m}_I, \hat{n}_I)} &= -3\pi^{2p+1}\mathcal{V}^{2p+1} \int_0^\infty dx dy x^{p-\frac{1}{2}} y^{p-\frac{1}{2}} e^{-\frac{\pi\mathcal{V}}{\Omega_2} [y|\hat{m}_1 + \hat{m}_2\Omega|^2 + x|\hat{n}_1 + \hat{n}_2\Omega|^2]} \\ &= -3(\Gamma(p + \frac{1}{2}))^2 \frac{\Omega_2^{p+\frac{1}{2}}}{|\hat{m}_1 + \hat{m}_2\Omega|^{2p+1}} \frac{\Omega_2^{p+\frac{1}{2}}}{|\hat{n}_1 + \hat{n}_2\Omega|^{2p+1}}. \end{aligned} \quad (5.12)$$

Summing (5.9) over  $(\hat{m}_I, \hat{n}_I)$  we see that  $\mathcal{I}_p$  satisfies the recursion relations

$$\mathcal{I}_p = -3 \frac{(\Gamma(p + \frac{1}{2}))^2}{(p - \frac{3}{2})(p + 2)} \sum_{(\hat{m}_I, \hat{n}_I)'} (\det M)^{-3} Z_{p+\frac{1}{2}}^{(\hat{m}_I)} Z_{p+\frac{1}{2}}^{(\hat{n}_I)} + \frac{4}{(p - \frac{3}{2})(p + 2)} \mathcal{I}_{p+1} \quad (5.13)$$

where

$$Z_s^{(\hat{m}_I)} = \frac{\Omega_2^s}{|\hat{m}_1 + \hat{m}_2 \Omega|^{2s}}, \quad Z_s^{(\hat{n}_I)} = \frac{\Omega_2^s}{|\hat{n}_1 + \hat{n}_2 \Omega|^{2s}} \quad (5.14)$$

(so that  $\sum_{(\hat{m}_1, \hat{m}_2) \neq (0,0)} Z_s^{(\hat{m}_I)} = Z_s^{(0,0)}$ ). The solution of this recursion relation gives

$$\frac{\pi^6}{4\mathcal{V}^3} \mathcal{E}_{(\frac{3}{2}, \frac{3}{2})} = I_1(\Omega, \bar{\Omega}) = S(\Omega, \bar{\Omega}) + R(\Omega, \bar{\Omega}), \quad (5.15)$$

where  $S$  is an infinite series,

$$S(\Omega, \bar{\Omega}) = \frac{\pi^6}{4\mathcal{V}^3} \sum_{p=0}^{\infty} c_p \mathcal{Z}_{(p+\frac{3}{2}, p+\frac{3}{2})}, \quad (5.16)$$

with

$$c_p = \frac{12}{\sqrt{\pi}} (1+2p) \frac{\Gamma(p+\frac{3}{2})}{\Gamma(p+4)}, \quad (5.17)$$

and where we have introduced the generalized non-holomorphic Eisenstein series

$$\mathcal{Z}_{(s,s')} = \sum_{(\hat{m}_I, \hat{n}_I)'} (\det M)^{s+s'-3} Z_s^{(\hat{m}_I)} Z_{s'}^{(\hat{n}_I)} \quad (5.18)$$

where  $\det M = \hat{m}_1 \hat{n}_2 - \hat{m}_2 \hat{n}_1$  and the Kronecker delta restricts the sums so that  $\det M \neq 0$ . Notice that this sum vanishes when  $s + s'$  is an even number because of the cancellation between the  $\det M > 0$  and  $\det M < 0$  contributions.

The expression  $R$  in (5.15) is a remainder that is given by

$$\begin{aligned} R(\Omega, \bar{\Omega}) &\equiv - \lim_{p \rightarrow \infty} \frac{2\pi^5}{\mathcal{V}^3} \frac{4\sqrt{\pi}}{\Gamma(p+\frac{1}{2})\Gamma(p+4)} \mathcal{I}_{p+2} \\ &= - \lim_{p \rightarrow \infty} \frac{8\pi^{\frac{11}{2}}}{\mathcal{V}^3} \frac{\pi^{2p+5} \mathcal{V}^{2p+5}}{\Gamma(p+\frac{1}{2})\Gamma(p+4)} \sum_{(\hat{m}_I, \hat{n}_I)'} (\det M)^{2p+2} \int_0^\infty dV V^{2p+4} \int_{\mathcal{F}} \frac{d^2\tau}{\tau_2^2} A e^{-\pi E}. \end{aligned} \quad (5.19)$$

After integration over  $V$  this becomes

$$R(\Omega, \bar{\Omega}) = - \lim_{p \rightarrow \infty} \frac{32\pi^5 p}{\mathcal{V}^3} \sum_{(\hat{m}_I, \hat{n}_I)'} \int_{\mathcal{F}} \frac{d^2\tau}{\tau_2^2} \frac{(2 \det M)^{2p+2} A(\tau)}{\left( \frac{|\hat{m}_1 + \hat{m}_2 \Omega| \tau + |\hat{n}_1 + \hat{n}_2 \Omega|^2}{\Omega_2 \tau_2} - 2 \det M \right)^{2p+5}}. \quad (5.20)$$

Clearly if  $\det M = 0$  the series  $S$  in (5.16) truncates at the first term and the remainder vanishes. When  $\det M \neq 0$ ,  $R$  is evaluated by taking the  $p \rightarrow \infty$  limit in (5.20), in which case the integrand is dominated by the values of  $\tau$  at which the magnitude of the denominator,

$$\left| \frac{|\hat{n}_1 + \hat{n}_2 \Omega| \tau + |\hat{m}_1 + \hat{m}_2 \Omega|^2}{\Omega_2 \tau_2} - 2 \det M \right|, \quad (5.21)$$

is minimized. It is easy to check that the minima of this expression arise when the first term vanishes, i.e., at  $\tau = \tau^0$ , where

$$\tau^0 = - \frac{\hat{m}_1 + \hat{m}_2 \Omega}{\hat{n}_1 + \hat{n}_2 \Omega}, \quad (5.22)$$

so that

$$\tau_2^0 = -\frac{\det M \Omega_2}{|\hat{n}_1 + \hat{n}_2 \Omega|^2}. \quad (5.23)$$

Setting  $\tau = \tau^0 + \epsilon$  and taking the limit  $p \rightarrow \infty$  for values of  $\hat{m}^I$  and  $\hat{n}^I$  such that  $\det M \neq 0$  gives

$$\begin{aligned} R(\Omega, \bar{\Omega}) &= -\lim_{p \rightarrow \infty} \frac{32\pi^5 p}{\mathcal{V}^3} \sum_{(\hat{m}_I, \hat{n}_I)'} \frac{A(\tau^0)}{|2 \det M|^3 (\tau_2^0)^2} \int d^2 \epsilon e^{-2p \log(1 - (\tau_2^0)^{-2} |\epsilon|^2)} \\ &= -\frac{2\pi^6}{\mathcal{V}^3} \sum_{(\hat{m}_I, \hat{n}_I)'} (\det M)^{-3} A\left(\frac{\hat{m}_1 + \hat{m}_2 \Omega}{\hat{n}_1 + \hat{n}_2 \Omega}\right). \end{aligned} \quad (5.24)$$

In summary, the complete solution naturally separates into contributions from the sector with  $\det M = 0$  and the sector with  $\det M \neq 0$ ,

$$\mathcal{E}_{\left(\frac{3}{2}, \frac{3}{2}\right)} = \mathcal{E}_{\left(\frac{3}{2}, \frac{3}{2}\right)}^{\det M \neq 0} + \mathcal{E}_{\left(\frac{3}{2}, \frac{3}{2}\right)}^{\det M = 0}. \quad (5.25)$$

In this expression we have

$$\begin{aligned} \mathcal{E}_{\left(\frac{3}{2}, \frac{3}{2}\right)}^{\det M \neq 0} &= \sum_{p=0}^{\infty} \frac{12}{\sqrt{\pi}} (1+2p) \frac{\Gamma(p + \frac{3}{2})}{\Gamma(p+4)} Z_{(p+\frac{3}{2}, p+\frac{3}{2})} - \\ &\quad - 8 \sum_{(\hat{m}_I, \hat{n}_I)'} \frac{\delta_{\det M \neq 0}}{(\det M)^3} A\left(\frac{\hat{m}_1 + \hat{m}_2 \Omega}{\hat{n}_1 + \hat{n}_2 \Omega}\right), \end{aligned} \quad (5.26)$$

while

$$\mathcal{E}_{\left(\frac{3}{2}, \frac{3}{2}\right)}^{\det M = 0} = \sum_{(\hat{m}_I, \hat{n}_I)'} \delta_{\det M = 0} Z_{\frac{3}{2}}^{(\hat{m}_I)} Z_{\frac{3}{2}}^{(\hat{n}_I)}. \quad (5.27)$$

To conclude this subsection we note that the sum of the remainder and the series can be reexpressed in a more compact but rather formal manner by introducing the quantity

$$Y_{(\hat{m}, \hat{n})} = \det M^2 Z_1^{(\hat{m}_I)} Z_1^{(\hat{n}_I)} \equiv \frac{\det M^2 \Omega_2^2}{|\hat{m}_1 + \hat{m}_2 \Omega|^2 |\hat{n}_1 + \hat{n}_2 \Omega|^2} = \frac{\tilde{\Omega}_2^2}{\tilde{\Omega}_1^2 + \tilde{\Omega}_2^2}, \quad (5.28)$$

where

$$\tilde{\Omega} \equiv \tilde{\Omega}_1 + i\tilde{\Omega}_2 = M \cdot \Omega = \frac{\hat{m}_1 + \hat{m}_2 \Omega}{\hat{n}_1 + \hat{n}_2 \Omega}. \quad (5.29)$$

Summing over  $p$  in  $S$  for  $\det M \neq 0$  gives

$$\begin{aligned} S^{(\det M \neq 0)} &= \frac{\pi^6}{\mathcal{V}^3} \sum_{(\hat{m}, \hat{n})'} (\det M)^{-3} \left( 20Y_{(\hat{m}, \hat{n})}^{-\frac{3}{2}} - 18Y_{(\hat{m}, \hat{n})}^{-\frac{1}{2}} + \frac{3}{2}Y_{(\hat{m}, \hat{n})}^{\frac{1}{2}} \right) + \\ &\quad + \frac{2\pi^6}{\mathcal{V}^3} \sum_{(\hat{m}, \hat{n})'} \frac{\sqrt{1 - Y_{(\hat{m}, \hat{n})}}}{(\det M)^3} \left( 4Y_{(\hat{m}, \hat{n})}^{-\frac{1}{2}} - 10Y_{(\hat{m}, \hat{n})}^{-\frac{3}{2}} \right), \end{aligned} \quad (5.30)$$

while expanding the function  $A$  in the remainder  $R$  we find

$$\begin{aligned} R &= \frac{\pi^6}{\mathcal{V}^3} \sum_{(\hat{m}, \hat{n})'} (\det M)^{-3} \left( 8\tilde{\Omega}_2^{-1} - 10\tilde{\Omega}_2 Y_{(\hat{m}, \hat{n})}^{-2} + 8\tilde{\Omega}_2 Y_{(\hat{m}, \hat{n})}^{-1} - 10\tilde{\Omega}_2^{-1} Y_{(\hat{m}, \hat{n})}^{-1} \right) - \\ &\quad - \frac{2\pi^6}{\mathcal{V}^3} \sum_{(\hat{m}, \hat{n})'} \frac{\sqrt{1 - Y_{(\hat{m}, \hat{n})}}}{(\det M)^3} \left( 4Y_{(\hat{m}, \hat{n})}^{-\frac{1}{2}} - 10Y_{(\hat{m}, \hat{n})}^{-\frac{3}{2}} \right). \end{aligned} \quad (5.31)$$

The  $\hat{m}^I$  and  $\hat{n}^I$  sums in the individual terms in both (5.30) and (5.31) are divergent (even though the solution (5.26) is not) and must be defined by zeta function regularization, so these expressions are rather formal. Adding them together we see that the  $\det M \neq 0$  sector simplifies since the square roots cancel with those in  $R$ . As a result, the sum of (5.27) and (5.26) leads to the formal expression

$$\begin{aligned} \mathcal{E}_{(\frac{3}{2}, \frac{3}{2})} &= 6\mathcal{Z}_{(\frac{1}{2}, \frac{1}{2})} - 72\mathcal{Z}_{(-\frac{1}{2}, -\frac{1}{2})} + 80\mathcal{Z}_{(-\frac{3}{2}, -\frac{3}{2})} + 64\mathcal{Z}_{(0, -1)} - 80\mathcal{Z}_{(-2, -1)} \\ &+ \sum_{(\hat{m}_I, \hat{n}_I)'} \delta_{\det M=0} Z_{\frac{3}{2}}^{(\hat{m}_I)} Z_{\frac{3}{2}}^{(\hat{n}_I)}. \end{aligned} \quad (5.32)$$

## 5.2 Inhomogeneous Laplace equation

In order to derive the Laplace equation satisfied by  $\mathcal{E}_{(\frac{3}{2}, \frac{3}{2})}$  we apply the Laplace operator  $\Delta_\Omega = 4\Omega_2^2 \partial_\Omega \bar{\partial}_\Omega$  to  $I_1$ , defined in (5.1). We then use the fact that

$$\Delta_\Omega e^{-\pi E} = \Delta_\tau e^{-\pi E}, \quad (5.33)$$

followed by two integrations by parts (as in the step from (4.4) to (4.6)) and the fact that  $\Delta_\tau A = 12(A - \tau_2 \delta(\tau_1))$ . The result is that  $\mathcal{E}_{(\frac{3}{2}, \frac{3}{2})}$  has to satisfy the Laplace equation,

$$\Delta_\Omega \mathcal{E}_{(\frac{3}{2}, \frac{3}{2})} = 12 \mathcal{E}_{(\frac{3}{2}, \frac{3}{2})} - 6 \mathcal{Z}_{(\frac{3}{2}, \frac{3}{2})}, \quad (5.34)$$

where  $\mathcal{Z}_{(3/2, 3/2)} \equiv Z_{3/2} Z_{3/2}$ .

It is easy to check that the explicit expression (5.26), which came from evaluating the two-loop integral directly, indeed satisfies this equation. For simplicity we will here show instead that the compact form (5.32) satisfies the equation. Firstly, note that the generalized series  $\mathcal{Z}_{(s, s)}$  in (5.18) satisfies

$$\Delta_\Omega \mathcal{Z}_{(s, s')} = (s + s')(s + s' - 1) \mathcal{Z}_{(s, s')} - 4ss' \mathcal{Z}_{(s+1, s'+1)}, \quad (5.35)$$

as shown in appendix C. Using this identity, the action of the  $Sl(2, \mathbf{Z})$  Laplacian on the solution (5.32), it is easily seen that the first line of  $\mathcal{E}_{(3/2, 3/2)}$  in (5.32) satisfies

$$\begin{aligned} [\Delta_\Omega - 12] &\left( 6\mathcal{Z}_{(\frac{1}{2}, \frac{1}{2})} - 72\mathcal{Z}_{(-\frac{1}{2}, -\frac{1}{2})} + 80\mathcal{Z}_{(-\frac{3}{2}, -\frac{3}{2})} + 64\mathcal{Z}_{(0, -1)} - 80\mathcal{Z}_{(-2, -1)} \right) = \\ &= -6 \sum_{(\hat{m}_I, \hat{n}_I)'} (1 - \delta_{\det M=0}) Z_{\frac{3}{2}}^{(\hat{m}_I)} Z_{\frac{3}{2}}^{(\hat{n}_I)}, \end{aligned} \quad (5.36)$$

and the second line of the  $\mathcal{E}_{(3/2, 3/2)}$  in (5.32) satisfies

$$\begin{aligned} \Delta_\Omega \sum_{(\hat{m}_I, \hat{n}_I)'} \delta_{\det M=0} Z_{\frac{3}{2}}^{(\hat{m}_I)} Z_{\frac{3}{2}}^{(\hat{n}_I)} &= \sum_{(\hat{m}_I, \hat{n}_I)'} \delta_{\det M=0} \left[ 6Z_{\frac{3}{2}}^{(\hat{m}_I)} Z_{\frac{3}{2}}^{(\hat{n}_I)} - 9Z_{\frac{5}{2}}^{(\hat{m}_I)} Z_{\frac{5}{2}}^{(\hat{n}_I)} \right] \\ &= 6 \sum_{(\hat{m}_I, \hat{n}_I)'} \delta_{\det M=0} Z_{\frac{3}{2}}^{(\hat{m}_I)} Z_{\frac{3}{2}}^{(\hat{n}_I)}, \end{aligned} \quad (5.37)$$

where we used in the last term that for  $s + s' > 3$  the generalized Eisenstein series for  $\det M = 0$  are vanishing. By summing (5.36) and (5.37), one shows that the equation (5.34) is satisfied.

It seems very likely that the Laplace equation (5.34) could also be derived by supersymmetry considerations. These would generalize the considerations of [6] where the Laplace eigenvalue equation for the  $l_s^{-2} \mathcal{R}^4$  interaction (1.4) was derived by considering the  $O(l_s^6)$  modifications to the supersymmetry transformations that relate the  $O(l_s^{-2})$  terms to the  $O(l_s^{-8})$  classical action. Supersymmetry similarly mixes the  $l_s^4 D^6 R^4$  interaction with the classical action, which requires a new  $O(l_s^{12})$  modification to the supersymmetry transformations. However, a qualitative new feature that first arises in this case is that the  $O(l_s^6)$  supersymmetry transformations also mix  $l_s^4 D^6 R^4$  with  $l_s^{-2} \mathcal{R}^4$  and other terms of the same order. This explains the generic origin of the inhomogeneous term, although have not studied this in any detail<sup>7</sup>.

### 5.3 Properties of $\mathcal{E}_{(\frac{3}{2}, \frac{3}{2})}(\Omega, \bar{\Omega})$

The solution (5.26) is rather awkward to analyze directly so we will here analyze those properties of  $\mathcal{E}_{(\frac{3}{2}, \frac{3}{2})}$  that can be seen directly from the structure of the Laplace equation (5.34) with rather little work.

To separate perturbative and non-perturbative contributions we write  $\mathcal{E}_{(\frac{3}{2}, \frac{3}{2})}(\Omega, \bar{\Omega})$  in terms of a Fourier expansion of the form

$$\mathcal{E}_{(\frac{3}{2}, \frac{3}{2})}(\Omega, \bar{\Omega}) = \tilde{\mathcal{E}}_{(\frac{3}{2}, \frac{3}{2})}^{(0)}(\Omega_2) + \sum_{k \neq 0} \tilde{\mathcal{E}}_{(\frac{3}{2}, \frac{3}{2})}^{(k)}(\Omega_2) e^{2ik\pi\Omega_1}. \quad (5.38)$$

The dependence on  $\Omega_1$  enters through the phase factor  $e^{2ik\pi\Omega_1}$ , that accompanies the non-zero mode. This is characteristic of a  $D$ -instanton contribution which comes from the double sum of  $D$ -instantons with charges  $k_1$  and  $k_2$ , where  $k_1 + k_2 = k$ . There is a corresponding exponentially decreasing coefficient,  $\tilde{\mathcal{E}}_{(3/2, 3/2)}^{(k)}$ , that should behave as  $e^{-2\pi(|k_1|+|k_2|)\Omega_2}$  at weak coupling ( $\Omega_2 \rightarrow \infty$ ). The zero mode,  $\tilde{\mathcal{E}}_{(3/2, 3/2)}^{(0)}$ , contains the piece that is a power-behaved function of the inverse string coupling constant,  $\Omega_2$  which is interpreted as a perturbative string contribution. There will also be an exponentially decreasing contribution to the zero mode piece, which is interpreted as a double  $D$ -instanton contribution in which the instanton charges are equal and opposite in sign ( $k_1 = -k_2$ ).

(a) **The zero mode contribution**  $\tilde{\mathcal{E}}_{(\frac{3}{2}, \frac{3}{2})}^{(0)}(\Omega_2)$ . The zero mode in (5.38) satisfies the equation

$$\begin{aligned} & (\Omega_2^2 \partial_{\Omega_2}^2 - 12) \tilde{\mathcal{E}}_{(\frac{3}{2}, \frac{3}{2})}^{(0)}(\Omega_2) = \\ & = -6 \left( (2\zeta(3)\Omega_2^{\frac{3}{2}} + 4\zeta(2)\Omega_2^{-\frac{1}{2}})^2 + (8\pi)^2 \Omega_2 \sum_{k \neq 0} k^2 \mu^2(k, \frac{3}{2}) \mathcal{K}_1^2(2\pi|k|\Omega_2) \right), \quad (5.39) \end{aligned}$$

where the right-hand side comes from a Fourier expansion of  $Z_{3/2}^2$ . The factor  $(2\zeta(3)\Omega_2^{3/2} + 4\zeta(2)\Omega_2^{-1/2})^2$  comes from the square of the zero mode of  $Z_{3/2}$  (defined by the first line in (1.5) with  $s = 3/2$ ) whereas the term involving the square of Bessel functions  $\mathcal{K}_1^2$  comes

---

<sup>7</sup>We are grateful to Savdeep Sethi for discussions on this issue

from the modes with non-zero  $k$ , which arise as a sum over  $D$ -instanton anti  $D$ -instanton pairs with  $k_1 = -k_2$  and  $|k_1| + |k_2| = k$ . The quantity  $\mu(k, 3/2) = \sum_{d|k} d^{-2}$  is the  $D$ -instanton measure factor [2].

Consider first the solution for the perturbative part of  $\tilde{\mathcal{E}}_{(3/2, 3/2)}^{(0)}$ , which is a sequence of power-behaved terms. The general solution for the power behaved terms that satisfy (5.39) is

$$\tilde{\mathcal{E}}_{(\frac{3}{2}, \frac{3}{2})}^{(0) \text{ pert}} = 4\zeta(3)^2 \Omega_2^3 + 8\zeta(3)\zeta(2)\Omega_2 + \frac{48}{5}\zeta(2)^2\Omega_2^{-1} + \alpha \Omega_2^4 + \beta \Omega_2^{-3}, \quad (5.40)$$

where the coefficients  $\alpha$  and  $\beta$  are not determined directly by (5.39) because the terms  $\Omega_2^4$  and  $\Omega_2^{-3}$  individually satisfy the homogeneous equation. It is easy to see from the solution that the  $\Omega_2^4$  term is absent, so  $\alpha = 0$  (it would obviously not have made sense for  $\alpha$  to be non-zero since a  $\Omega_2^4$  term would be more singular than the tree-level  $\Omega_2^3$  term). The coefficient  $\beta$  represents a three-loop contribution in string perturbation theory. The value of  $\beta$  requires separate discussion and is the subject of the next subsection.

The remaining coefficients in (5.40) are determined directly by (5.39). These correspond to the tree-level, one-loop and two-loop contributions to the  $D^6 R^4$  interaction. The leading  $\Omega_2^3$  term in (5.40) represents the tree-level contribution and has precisely the expected coefficient that matches the string tree-level calculation that is reviewed in appendix A. The coefficient of the one-loop term proportional to  $\Omega_2$  is exactly one half of the value that would have arisen if we had assumed that  $\mathcal{E}_{(3/2, 3/2)}$  were given by  $Z_{3/2}^2$ , as in [20]. But the analysis of the one-loop four-graviton scattering amplitude in type II string theory in [14] determined that the correct value for this coefficient is one half of the value contained in  $Z_{3/2}^2$ , so our value agrees with the correct value. In addition, the expression (5.40) includes the two-loop term  $48\zeta(2)^2 \Omega_2^{-1}/5$ . Since this has not yet been calculated in string perturbation theory this gives a prediction that should be calculable by an extension of [15, 18, 11, 16, 17] to include the first non-leading term in the expansion of the string-theory two-loop term in powers of the external momenta.

In addition to the power behaved piece,  $\tilde{\mathcal{E}}_{(3/2, 3/2)}^{(0)}$  contains an exponentially decreasing piece that comes from charge- $\hat{k}$   $D$ -instanton and charge- $(-\hat{k})$  anti  $D$ -instanton pairs that contribute to the sector with  $k = k_1 + k_2 = 0$ . This can again be discovered directly from the solution or else by setting  $\hat{k} = k_1 = -k_2$  in the following analysis of the more general charge- $k$  sectors, which contain only non-perturbative contributions.

**(b) Non-perturbative terms,  $\tilde{\mathcal{E}}_{(\frac{3}{2}, \frac{3}{2})}^{\text{nonpert}(k)}(\Omega_2)$ .** Having determined the perturbative contributions, the remaining contributions involve single charge- $k$   $D$ -instantons or pairs of  $D$ -instantons with net charge  $k$ .

Expanding (5.34) in Fourier modes gives an equation for each mode of the form

$$\begin{aligned} & [\Omega_2^2 (\partial_{\Omega_2}^2 - 4\pi^2 k^2) - 12] \tilde{\mathcal{E}}_{(\frac{3}{2}, \frac{3}{2})}^{\text{nonpert}(k)}(\Omega_2) = \\ & = -384\pi^2 \Omega_2 \sum_{\substack{k_1 \neq 0, k_2 \neq 0 \\ k_1 + k_2 = k}} |k_1 k_2| \mu(k_1, \frac{3}{2}) \mu(k_2, \frac{3}{2}) \mathcal{K}_1(2\pi|k_1|\Omega_2) \mathcal{K}_1(2\pi|k_2|\Omega_2) - \end{aligned}$$

$$-96\pi \left( 2\zeta(3)\Omega_2^{\frac{3}{2}} + 4\zeta(2)\Omega_2^{-\frac{1}{2}} \right) \sum_{k_1 \neq 0} |k_1| \mu(k_1, \frac{3}{2}) \mathcal{K}_1(2\pi|k_1|\Omega_2). \quad (5.41)$$

Using the asymptotic form for the modified Bessel function  $\mathcal{K}_1(z) \sim \sqrt{\pi/2z} e^{-z}$ , the large- $\Omega_2$  limit of the solution is easy to determine. For a general value of  $k = k_1 + k_2$  it has the form

$$\sum_{k_1} P_{k_1}(\Omega_2) e^{-2\pi(|k_1|+|k-k_1|)\Omega_2} e^{2\pi i k \Omega_1}, \quad (5.42)$$

where the functions  $P_k \sim \Omega_2^{-p_k}$  with positive  $p_k$ . When  $k_1$  and  $k_2 (= k - k_1)$  both have the same sign the action is equal to the charge ( $|k_1| + |k - k_1| = k$ ). But otherwise the action is less than the charge. In particular, there is a  $k = 0$  contribution to  $\mathcal{E}_{(3/2,3/2)}^{(0)}$  due to  $D$ -instanton — anti  $D$ -instanton pairs, mentioned above, that has the form

$$-64\pi^2 \sum_k |\hat{k}| \mu(\hat{k}, \frac{3}{2})^2 \left( \frac{1}{4\pi|\hat{k}|\Omega_2} + \dots \right) e^{-4\pi|\hat{k}|\Omega_2}. \quad (5.43)$$

#### 5.4 The three-loop term

We will now determine the three-loop coefficient,  $\beta$ , of the  $\Omega_2^{-3}$  term in (5.40). First we should note that a general solution of the Laplace equation (1.8) can be written as the sum of a particular solution and a multiple of  $Z_4$ , which is the solution of the homogeneous Laplace equation,  $\Delta Z_4 = 12 Z_4$ . Recall also that  $Z_4 = \sum_{(m,n) \neq (0,0)} \Omega_2^4 / |m + n\Omega|^8$  has the large- $\Omega_2$  expansion

$$Z_4 = 2\zeta(8)\Omega_2^4 + \frac{5\pi}{8} \zeta(7) \Omega_2^{-3} + \dots \quad (5.44)$$

where ... denotes exponentially suppressed terms. However, the special solution  $\mathcal{E}_{(3/2,3/2)}$  that we obtained from the two-loop supergravity expression is known not to have a  $\Omega_2^4$  piece ( $\alpha = 0$  in (5.40)), so that the coefficient of  $Z_4$  in the general solution must be zero. The question remains as to whether  $\mathcal{E}_{(3/2,3/2)}$  contains a  $\beta \Omega_2^{-3}$  term.

To study this we multiply the left-hand and right-hand sides of the inhomogeneous Laplace equation (1.8) by the Eisenstein series  $Z_4$  and integrate over a fundamental domain of  $\Omega$ . Since the relevant integrals diverge at the boundary  $\Omega_2 \rightarrow \infty$ , we will introduce a cut-off at  $\Omega_2 = L$  and consider the  $L \rightarrow \infty$  limit. Denoting the cut-off fundamental domain by  $\mathcal{F}_L$ , the resulting equation is

$$\int_{\mathcal{F}_L} \frac{d^2\Omega}{\Omega_2^2} Z_4 \Delta \mathcal{E}_{(\frac{3}{2}, \frac{3}{2})} = 12 \int_{\mathcal{F}_L} \frac{d^2\Omega}{\Omega_2^2} Z_4 \mathcal{E}_{(\frac{3}{2}, \frac{3}{2})} - 6 \int_{\mathcal{F}_L} \frac{d^2\Omega}{\Omega_2^2} Z_4 Z_{\frac{3}{2}}. \quad (5.45)$$

Integrating the left-hand side by parts and using the fact that  $\Delta Z_4 = 12 Z_4$ , gives

$$\begin{aligned} \int_{\mathcal{F}_L} \frac{d^2\Omega}{\Omega_2^2} Z_4 \Delta \mathcal{E}_{(\frac{3}{2}, \frac{3}{2})} &= \int_{\mathcal{F}_L} \frac{d^2\Omega}{\Omega_2^2} \Delta Z_4 \mathcal{E}_{(\frac{3}{2}, \frac{3}{2})} + \int_{-\frac{1}{2}}^{\frac{1}{2}} d\Omega_1 \left( Z_4 \partial_{\Omega_2} \mathcal{E}_{(\frac{3}{2}, \frac{3}{2})} - \partial_{\Omega_2} Z_4 \mathcal{E}_{(\frac{3}{2}, \frac{3}{2})} \right) \Big|_{\Omega_2=L} \\ &= 12 \int_{\mathcal{F}_L} \frac{d^2\Omega}{\Omega_2^2} Z_4 \mathcal{E}_{(\frac{3}{2}, \frac{3}{2})} + \\ &\quad + \int_{-\frac{1}{2}}^{\frac{1}{2}} d\Omega_1 \left( Z_4 \partial_{\Omega_2} \mathcal{E}_{(\frac{3}{2}, \frac{3}{2})} - (\partial_{\Omega_2} Z_4) \mathcal{E}_{(\frac{3}{2}, \frac{3}{2})} \right) \Big|_{\Omega_2=L}. \end{aligned} \quad (5.46)$$

Comparing (5.46) with (5.45) we see that

$$\int_{-\frac{1}{2}}^{\frac{1}{2}} d\Omega_1 \left( Z_4 \partial_{\Omega_2} \mathcal{E}_{(\frac{3}{2}, \frac{3}{2})} - (\partial_{\Omega_2} Z_4) \mathcal{E}_{(\frac{3}{2}, \frac{3}{2})} \right) \Big|_{\Omega_2=L \rightarrow \infty} = -6 \int_{\mathcal{F}_L} \frac{d^2 \Omega}{\Omega_2^2} Z_4 Z_{\frac{3}{2}}^2. \quad (5.47)$$

The left-hand side of this equation is simply a surface time that is easy to evaluate

$$\begin{aligned} & \int_{-\frac{1}{2}}^{\frac{1}{2}} d\Omega_1 \left( Z_4 \partial_{\Omega_2} \mathcal{E}_{(\frac{3}{2}, \frac{3}{2})} - (\partial_{\Omega_2} Z_4) \mathcal{E}_{(\frac{3}{2}, \frac{3}{2})} \right) \Big|_{\Omega_2=L \rightarrow \infty} = \\ & = -\zeta(8) (8\zeta(3)^2 L^6 + 48\zeta(3)\zeta(2)L^4 + 96\zeta(2)^2 L^2 + 14\beta). \end{aligned} \quad (5.48)$$

The right hand-side of (5.47) may be evaluated by unfolding the integral<sup>8</sup> onto the strip using  $Z_4 = 2\zeta(8) \sum_{\gamma \in Sl(2, \mathbf{Z})} \Im(\gamma \cdot \Omega)^4$  and the fact that  $Z_{\frac{3}{2}}^2$  is modular invariant, which gives

$$\begin{aligned} \frac{1}{2\zeta(8)} \int_{\mathcal{F}_L} \frac{d^2 \Omega}{\Omega_2^4} Z_4 Z_{\frac{3}{2}}^2 &= \int_0^L \frac{d\Omega_2}{\Omega_2^2} \Omega_2^4 \int_{-\frac{1}{2}}^{\frac{1}{2}} d\Omega_1 Z_{\frac{3}{2}}^2 \\ &= \frac{2}{3} \zeta(3)^2 L^6 + \zeta(3)\zeta(2) L^4 + 2\zeta(2)^2 L^2 + \\ &+ (8\pi)^2 \int_0^L d\Omega_2 \Omega_2^3 \sum_{k \neq 0} k^2 \mu(|k|, \frac{3}{2})^2 \mathcal{K}_1^2(2\pi|k|\Omega_2). \end{aligned} \quad (5.49)$$

Using the integral representation for the Bessel function given in appendix A we find that

$$\beta = \frac{384\pi^2}{7} \int_0^\infty d\Omega_2 \Omega_2^3 \sum_{k \neq 0} k^2 \mu(|k|, \frac{3}{2})^2 \mathcal{K}_1^2(2\pi|k|\Omega_2) = \frac{32}{7\pi^2} \sum_{k \geq 1} \frac{\mu(k, \frac{3}{2})^2}{k^2}, \quad (5.50)$$

which gives a non-zero value for the three-loop term. Recalling that  $\mu(n, s) = \sum_{m|n} n^{1-2s}$  and using an identity by Ramanujan quoted in [23]

$$\sum_{n=1}^{\infty} \frac{\mu(n, s)\mu(n, s')}{n^r} = \frac{\zeta(r)\zeta(r+2s-1)\zeta(r+2s'-1)\zeta(r+2s+2s'-2)}{\zeta(2r+2s+2s'-2)} \quad (5.51)$$

we find that the three-loop coefficient has the value

$$\beta = \frac{16}{189} \pi^2 \zeta(4). \quad (5.52)$$

We cannot compare this predicted coefficient with perturbative string theory since there are no explicit three-loop results. However, this number is in complete agreement with our

---

<sup>8</sup>This is the standard Rankin-Selberg trick which states that one can unfold integrals of Poincaré series onto the strip [22]

$$\int_{\mathcal{F}} \frac{d^2 \tau}{\tau_2^2} \sum_{\gamma \in \Gamma_\infty \backslash PSl(2, \mathbf{Z})} \psi(\gamma \cdot \tau) f(\tau) = \int_0^\infty \frac{d\tau_2}{\tau_2^2} \psi(\tau_2) \int_{-\frac{1}{2}}^{\frac{1}{2}} f(\tau) d\tau_1,$$

where  $\Gamma_\infty = \{ \begin{smallmatrix} 1 & n \\ 0 & 1 \end{smallmatrix}, n \in \mathbf{Z} \}$  and  $\mathcal{F} = PSl(2, \mathbf{Z}) \backslash \mathcal{H}$  is the fundamental domain for  $Sl(2, \mathbf{Z})$  and  $\mathcal{H} = \{ \tau = \tau_1 + i\tau_2 | \tau_2 > 0 \}$  is the upper half-plane.



earlier calculation of the three-loop coefficient in type IIA string theory that is contained in [10] (see also [21]). There it was shown that the one-loop four-graviton amplitude of eleven-dimensional supergravity compactified on a two-torus gives rise to a series of higher-derivative terms in the nine-dimensional type IIA effective action of the form

$$\begin{aligned}
 A_4^{(1)} = & (4\pi^8 l_{11}^{15} r_A^{-1}) \hat{K} r_A \left[ 2\zeta(3) e^{-2\phi^A} + \frac{2\pi^2}{3r_A^2} + \frac{2\pi^2}{3} - 8\pi^2 r_A l_s (-\mathcal{W}^s)^{\frac{1}{2}} \right. \\
 & + 8\pi^{\frac{3}{2}} \sum_{n=2}^{\infty} \left( \Gamma(n - \frac{1}{2}) \zeta(2n - 1) \frac{r_A^{2(n-1)}}{n!} (l_s^2 \mathcal{W}^s)^n \right. \\
 & \left. \left. + \sqrt{\pi} \Gamma(n - 1) \zeta(2n - 2) \frac{e^{2(n-1)\phi^A}}{n!} (l_s^2 \mathcal{W}^s)^n \right) \right] + \text{non - perturbative}, \quad (5.53)
 \end{aligned}$$

where

$$(\mathcal{W}^s)^n = (\mathcal{G}_{ST}^s)^n + (\mathcal{G}_{TU}^s)^n + (\mathcal{G}_{US}^s)^n, \quad (5.54)$$

and

$$(\mathcal{G}_{ST}^s)^n = \int_0^1 d\omega_3 \int_0^{\omega_3} d\omega_2 \int_0^{\omega_2} d\omega_1 (s\omega_1(\omega_3 - \omega_2) + t(\omega_2 - \omega_1)(1 - \omega_3))^n. \quad (5.55)$$

The terms in the third line of (5.53) give higher-loop contributions to the ten-dimensional effective action of the type IIA theory. The term with  $n = 2$  gives the two-loop  $D^4 R^4$  term in the IIA theory that matches the same term in the type IIB theory that was the subject of [10]. The term with  $n = 3$  in the third line of (5.53) contributes to the three-loop  $D^6 R^4$  term in the IIA theory and has the value

$$S_{D^6 R^4}^{(IIA)} = l_s^4 \frac{1}{4 \cdot 96 \cdot (4\pi)^7} \frac{16}{189} \pi^2 \zeta(4) \int d^{10}x \sqrt{-g^A} e^{4\phi^A} D^6 R^4. \quad (5.56)$$

Including the absolute normalisation this type IIA expression and the type IIB expression (3.4), we find a perfect match between the two values for the three-loop coefficient for the  $D^6 R^4$  in superstring theory. This may be of interest since there seems to be no reason, a priori, for the three-loop four-graviton amplitudes to be equal in the two theories as pointed out in<sup>9</sup> [10].

## 6. Higher Loops and Higher Order Interactions

The results of this paper extend the systematic interpretation of loop diagrams of eleven-dimensional supergravity compactified on  $\mathcal{T}^2$ . The theory obviously has ultraviolet divergences that indicate that the quantum version of the theory cannot be defined by conventional quantum field theory methods. However, at least for the examples we have studied, the divergences can be subtracted by introducing cutoff-dependent counterterms with values that are determined by duality properties expected from the correspondence with type

---

<sup>9</sup>The amplitudes only differ in the sign of the odd-odd spin structures. At one and two loops the odd-odd spin structures vanish, so the amplitudes must be equal, but they need not vanish at three or more loops.

IIA or IIB string theory on a circle. Indeed, since the UV divergences are local they are proportional to the volume of the torus  $\mathcal{V}$  and vanish in the limit  $\mathcal{V} \rightarrow 0$  that corresponds to the ten-dimensional type IIB.

We would now like to analyze the potential divergences at higher orders to see if these systematics can lead to further insights. Recall that the eleven-dimensional one-loop four-graviton amplitude has a superficial UV divergence of order  $\Lambda^{11}$  — where  $\Lambda$  is an arbitrary momentum cutoff. However, the amplitude has an overall kinematic factor of  $\hat{K}^4$  (where the linearized Weyl tensor,  $\hat{K}$ , has dimension two) multiplying a scalar field theory box diagram which has a cubic divergence of order  $\Lambda^3$ . Upon compactification there are finite contributions to this integral with dependence on the volume determined by dimensional analysis to be  $1/\mathcal{V}_n^{3/2}$  (where  $n = 1$  for a circular compactification and  $n = 2$  for  $\mathcal{T}^2$ ). These finite terms come from the non-zero windings of the loop around homology cycles of  $\mathcal{T}^n$  whereas the divergent term comes from the zero winding number sector and does not depend on the moduli of  $\mathcal{T}^n$ . The dilaton-dependent coefficient,  $Z_{3/2}$ , of the IIB  $\mathcal{R}^4$  interaction was determined in this way from the one-loop four-graviton scattering in [3]. At the same time, comparison of the IIA and IIB theory at finite  $\mathcal{V}$  resulted in an unambiguous value for the counterterm that subtracts the  $\Lambda^3$  divergence, resulting in a finite value for the IIA limit,  $R_{11} \rightarrow 0$ . This fixed the value of the one-loop amplitude of the IIA theory and hence the  $R^4$  interaction in eleven dimensions.

The coefficient,  $Z_{5/2}$ , for the  $D^4\mathcal{R}^4$  interaction was determined in [10] by considering the two-loop supergravity diagrams, together with a one-loop diagram in which one vertex is the one-loop counterterm. The superficial divergence of the two-loop amplitude is  $\Lambda^{20}$ . However, as shown in [1], the two-loop diagrams reduce to a sum of terms in which there is an overall factor of  $S^2\hat{\mathcal{R}}^4$  (together with the terms with coefficients  $T^2\hat{\mathcal{R}}^4$  and  $U^2\hat{\mathcal{R}}^4$ ) multiplying a couple of scalar field theory two-loop diagrams. This external factor has dimension  $[\Lambda]^{12}$  and the scalar two-loop diagram has a new two-loop divergence of order  $\Lambda^8$ . However, it also has two sub-divergences arising in the sectors where one loop has zero winding. This can be subtracted by adding the one-loop diagram in which one vertex is the one-loop counterterm that is of order  $\Lambda^3$ . This leaves an apparent  $\Lambda^5$  divergence. But there is a finite term proportional to  $\mathcal{V}_n^{-5/2}$  that arises from non-zero windings of the other loop around  $\mathcal{T}^n$ . In this case the finite  $D^4R^4$  interaction of the ten-dimensional type IIB limit ( $\mathcal{V}_2 \rightarrow 0$ ) arises from a one-loop sub-divergence that is rendered finite by adding the diagram with the one-loop counterterm.

### 6.1 Dimensional analysis and higher order terms

In this paper we have extended the above analysis to the next order in the momentum expansion of the two-loop amplitude. There are now two more external momenta so the apparent degree of divergence is reduced to  $\Lambda^6$ . However, the sectors in which the loops have non-zero windings around  $\mathcal{T}^2$ , which give a finite contribution proportional to  $\mathcal{V}_n^3$  so in this case we did not face any divergences — the integrals were all finite.

We can now ask whether contributions from higher-loop diagrams of eleven-dimensional supergravity can affect the results we have obtained from one or two loops. It was shown in [1] that all diagrams beyond one loop have an external factor of  $D^4\mathcal{R}^4$ . Using our analysis

this means that there can be no further contributions to the  $\mathcal{R}^4$  term. This argument motivates the statement that  $\mathcal{R}^4$  receives no perturbative string contributions beyond one loop since  $Z_{3/2}$  only contains a one string loop contribution [2]. However, we may well ask whether the results obtained from two-loop eleven-dimensional supergravity get modified by eleven-dimensional three-loop and higher-loop effects. For example, are higher powers of external momenta (ie, higher numbers of derivatives) pulled out into the prefactor multiplying the sum of diagrams at higher orders? Unfortunately, the systematics of maximally extended supergravity is still rather mysterious beyond two loops. For example, the set of three-loop diagrams motivated by unitarity cuts in [1] is incomplete (certain diagrams that have no two-particle cuts are missing).<sup>10</sup> It has so far proved too complicated to determine if the complete sum has higher powers of momenta in the external prefactor. Such extra external momentum factors would imply further non-renormalisation theorems. For example, if the sum of all three-loop diagrams turned out to have an external factor of  $D^8\mathcal{R}^4$  then it could not affect the two-loop supergravity calculations of this paper. This would imply that the  $D^4\mathcal{R}^4$  and  $D^6\mathcal{R}^4$  interactions would get no further perturbative contributions beyond two string loops. The situation with the eleven-dimensional supergravity perturbation theory would then be analogous to that encountered in ten-dimensional type II superstring perturbation theory. There, up to two loops supersymmetry acts point-wise in the moduli space of the world-sheet and non-renormalisation statements can then be deduced by knowing the behavior of the integrand [15, 11, 16, 17, 13, 18]. However, for three or more loops the integrand contains an explicit overall factor of  $D^4\mathcal{R}^4$  [24] and any further non-renormalisation theorems, such as for  $D^6\mathcal{R}^4$ , would only be apparent after integrating over the moduli.

However, if we assume that the cut-off procedure outlined above continues to make sense we can infer some perturbative string theory non-renormalisation statements even without detailed knowledge of the higher-loop terms in supergravity. For example, we can deduce that the expressions for the dilaton dependence of the  $D^4\mathcal{R}^4$  and  $D^6\mathcal{R}^4$  interactions presented in [10] and in this paper do not get modified by higher order terms. To see this let us focus on the three-loop diagrams. For simplicity we will consider the case of compactification on a circle of radius  $R_{11}$  to give the IIA theory. Such diagrams have the superficial degree of divergence of three-loop gravity, which is  $\Lambda^{29}$ . However, we know that the sum of diagrams has a factor  $D^4\mathcal{R}^4 \sim S^2\mathcal{R}^4$ , which lowers the superficial divergence to  $\Lambda^{17}$ . This power can be interpreted by associating  $\Lambda^3$  with one one-loop subdivergence, or  $\Lambda^6$  with two one-loop subdivergences, or  $\Lambda^8$  with the two-loop divergence. The one-loop divergences are regulated by including diagrams with the known counterterms.<sup>11</sup> Any remaining powers of  $\Lambda$  may be transmuted into inverse powers of  $R_{11}$  in the compactified theory. To make sense in string theory, the result must have an integer power of the string coupling  $g_s^2 = R_{11}^3$  in M-theory units (we must also remember the rule for the Mandelstam invariants,  $s = S/R_{11}$ ,  $t = T/R_{11}$  and  $u = U/R_{11}$ , where capital letters denote the eleven-dimensional invariants).

---

<sup>10</sup>MBG is grateful to Lance Dixon for many discussions on this point.

<sup>11</sup>In [10] it was argued that the regulated two-loop divergence has to vanish.

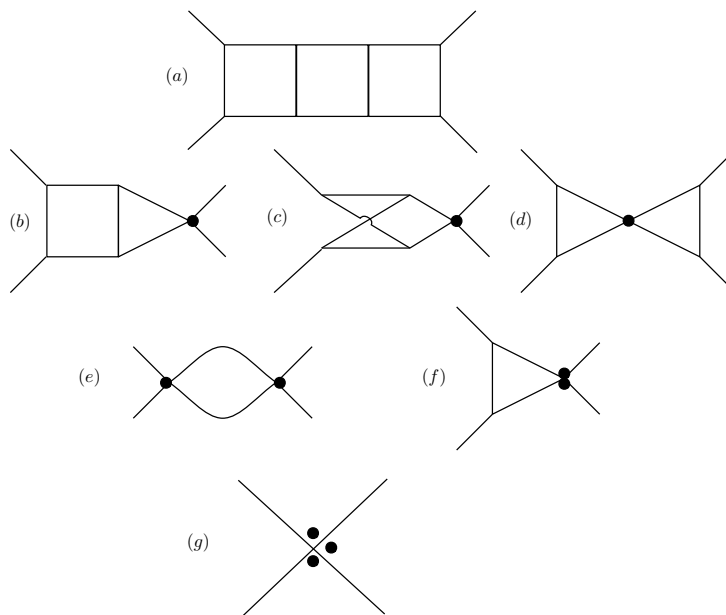

**Figure 3:** The schematic structure of the divergences of three-loop four-graviton amplitudes compactified on  $\mathcal{T}^1$  or  $\mathcal{T}^2$ . (a) The sum of the finite contributions to three-loop diagrams (only one out of very many diagrams is pictured). This should contribute to the  $D^{12} \mathcal{R}^4$  interaction. (b),(c),(d) The three distinct kinds of two-loop diagrams with a one-loop counterterm (represented by the blob) that is needed to cancel a one-loop subdivergence. These contribute to the  $D^{10} \mathcal{R}^4$  interaction. (e) A one-loop diagram with two one-loop counterterms, which should contribute to  $D^8 \mathcal{R}^4$ . (f) A one-loop diagram with a two-loop counterterm vertex, which was argued to vanish in [10]. (g) A new primitive three-loop divergence that makes no contribution in the zero volume limit that gives the ten-dimensional type II string theories.

As a first example, let us see if there can be a three-loop supergravity contribution that can be interpreted as a string theory tree-level  $D^4 \mathcal{R}^4 \sim S^2 \mathcal{R}^4$  interaction. For this to be the case we would need a power of  $1/R_{11}^5$  (coming from  $1/g_s^2$  and two powers from  $s^2 = S^2/R_{11}^2$ ). We would then reinterpret the 17 powers of  $\Lambda$  as  $\Lambda^{12}/R_{11}^5$ . However, this would correspond to four powers of  $\Lambda^3$ , or four one-loop subdivergences, which cannot arise at three loops!

This argument extends to the  $D^6 \mathcal{R}^4 \sim S^3 \mathcal{R}^4$  interaction. Now we have two extra powers of external momenta so the superficial degree of divergence is reduced to  $\Lambda^{15}$ . A tree-level contribution would require a power of  $1/R_{11}^6$  (taking into account  $s^3 = S^3/R_{11}^3$ ), leaving a net power of  $\Lambda^9$ . This could only be absorbed by three powers of  $\Lambda^3$ , but this would require three one-loop subdivergences. Such a contribution (see figure 3g) would only come from the zero winding number sector of all three loops and could not produce the requisite dependence on  $R_{11}$  that arises from non-zero windings.

However, there should be a non-zero three-loop supergravity contribution to the  $D^8 \mathcal{R}^4 \sim S^4 \mathcal{R}^4$  interaction, which has a superficial divergence of  $\Lambda^{13}$ . In this case a tree-level term behaves as  $R_{11}^{-7}$ , which leaves a net power of  $\Lambda^6$ , which corresponds to two one-loop divergences accompanied by two one-loop counterterms as shown in figure 3e. Further analysis

of this diagram strongly suggests that (when compactified on  $\mathcal{T}^2$ ) it should contribute the interaction,

$$l_s^6 \int d^{10}x \sqrt{-g} e^{3\phi/2} Z_{7/2} D^8 \mathcal{R}^4, \tag{6.1}$$

to the effective IIB theory. The function  $Z_{7/2}$  should also follow from supersymmetry.

Likewise, a contribution of the form

$$l_s^8 \int d^{10}x \sqrt{-g} e^{2\phi} \mathcal{E}_{(\frac{3}{2}, \frac{5}{2})} D^{10} \mathcal{R}^4, \tag{6.2}$$

should arise from the diagrams containing a counterterm for a single one-loop subdivergence shown in figures 3*b–d*. The modular function  $\mathcal{E}_{(3/2, 5/2)}$  is not determined by these very general arguments, but we know that it has a tree-level term proportional to  $\zeta(3)\zeta(5)$ , as can be seen from appendix A. In principle, this function should again be determined by supersymmetry using an extension of the argument of [6]. In this case there would be an  $O(l_s^{16})$  modification of the supersymmetry transformations that would mix  $D^{10} \mathcal{R}^4$  with the Einstein–Hilbert action. But recall that there are also  $O(l_s^6)$  and  $O(l_s^{10})$  modifications to the supersymmetry transformations that mix the  $l_s^{-2} Z_{3/2} \mathcal{R}^4$  and  $l_s^2 Z_{5/2} D^4 \mathcal{R}^4$  interactions (and other interactions of the same dimension) with the classical action. These transformations also mix the  $O(l_s^{-2})$  and  $O(l_s^2)$  interactions with  $l^6 D^6 \mathcal{R}^4$ . It plausibly follows by analogy with our understanding of the  $\mathcal{E}_{(3/2, 3/2)}$  that  $\mathcal{E}_{(3/2, 5/2)}$  satisfies a inhomogeneous Laplace equation of the form

$$\Delta_\Omega \mathcal{E}_{(\frac{3}{2}, \frac{5}{2})} = A \mathcal{E}_{(\frac{3}{2}, \frac{5}{2})} + B Z_{\frac{3}{2}} Z_{\frac{5}{2}}, \tag{6.3}$$

where  $A$  and  $B$  are constants that have not been determined.

Something qualitatively new happens at the next order. Consider the possible contribution to the  $D^{12} \mathcal{R}^4 \sim S^6 \mathcal{R}^4$  interaction coming from compactified eleven-dimensional supergravity. This interaction has dimension  $[\Lambda]^{20}$ , which reduces the apparent divergence of the three-loop diagrams to  $\Lambda^9$ . In this case a tree-level term would have a power  $1/R_{11}^9$  (noting that  $s^6 = S^6/R_{11}^6$ ) so the contribution to this interaction is given by a *finite* integral, which comes from a sum over all three-loop diagrams (represented by figure 3*a*). However, in this case there are two different terms in the tree-level expression given in appendix A. One of these has coefficient  $\zeta(9)$  and should be associated with an interaction of the form

$$l_s^{10} \int d^{10}x \sqrt{-g} e^{5\phi/2} Z_{9/2} D^{12} \mathcal{R}^4. \tag{6.4}$$

The other tree-level term has coefficient  $\zeta(3)^3$  and is associated with an interaction that could be written as

$$l_s^{10} \int d^{10}x \sqrt{-g} e^{5\phi/2} \mathcal{E}_{(\frac{3}{2}, \frac{3}{2}, \frac{3}{2})} D^{12} \mathcal{R}^4, \tag{6.5}$$

where  $\mathcal{E}_{(\frac{3}{2}, \frac{3}{2}, \frac{3}{2})}(\Omega, \bar{\Omega})$  is a new modular form satisfying a generalized version of our inhomogeneous Laplace equation.

We see, with the above reasoning, how the structure of the string tree-level four-graviton amplitude indicates an increasing degeneracy of dilaton-dependent modular functions as the order in  $l_s^2$  increase. It should be interesting to see how such a structure is in accord with the constraints of supersymmetry.

## 7. Summary and discussion of the eleven-dimensional limit

In this paper we have determined exact properties of the coupling constant dependence of the  $l_s^4 D^6 \mathcal{R}^4$  interaction in the low energy expansion of the type II string theories. The IIA theory only contains perturbative terms that are proportional to powers of the string coupling whereas the dependence on the complex coupling in the IIB theory is encoded in a modular function. This function,  $\mathcal{E}_{(3/2,3/2)}(\Omega, \bar{\Omega})$ , which satisfies a Laplace equation with a source term (5.34) is given in (5.26) as the sum of two terms,  $S$  and  $R$ . The first part  $S$  is an infinite series of terms proportional to  $\mathcal{Z}_{(p+3/2, p+3/2)}$  ( $p = 0, 1, \dots$ ) defined by (5.18) and  $R$  is given by (5.24).

We discussed properties of the function  $\mathcal{E}_{(3/2,3/2)}$  in terms of its Fourier modes that are proportional to  $e^{2\pi i k \Omega_1}$ . This is the decomposition into sectors of different  $D$ -instanton charges,  $k$ . The zero mode sector contains the ‘perturbative’ terms that are powers of  $\Omega_2 \equiv e^{-\phi}$ . We determined the coefficients of the four perturbative terms, which are proportional to  $\Omega_2^3$ ,  $\Omega_2$ ,  $\Omega_2^{-1}$  and  $\Omega_2^{-3}$ , corresponding to tree-level, one-loop, two-loop and three-loop contributions in string perturbation theory, respectively. The tree-level and one-loop terms precisely match string perturbation theory results whereas the value of the two-loop coefficient (the term with  $48/5 \zeta(2)^2$  in (5.40)) and the three-loop coefficient (the value of  $\beta$  given in (5.52)) have not yet been calculated in string theory and so are predictions. These properties followed by analyzing the Laplace equation rather than its explicit solution, together with the boundary condition that the leading power of  $\Omega_2$  contained in  $\mathcal{E}_{(3/2,3/2)}$  is the tree-level term in the weak coupling limit (which is easy to verify from the explicit solution). For completeness, we also extracted the three-loop coefficient of the type IIA theory from a formula in [10] and found that this was also equal to  $\beta$ . This may be of interest since equality of the four-graviton amplitudes in the IIA and IIB theories is not obvious beyond two loops.

The non zero-mode sector includes an infinite series of exponentially suppressed  $D$ -instanton terms that are proportional to  $e^{2\pi i k \Omega}$ , where  $k \neq 0$  is the  $D$ -instanton charge. There is also an infinite series of terms corresponding to pairs of  $D$ -instantons with charges  $k_1$  and  $k_2$ . Each term is proportional to  $e^{2\pi i(k_1+k_2)\Omega_1} e^{-2\pi i(|k_1|+|k_2|)\Omega_2}$ . In general for these terms the magnitude of the  $D$ -instanton charge is smaller than the action since  $|k_1 + k_2| \leq |k_1| + |k_2|$ . Equality only holds for the cases where both  $k_1$  and  $k_2$  have the same sign. The terms in which  $k_1 = -k_2 \equiv \hat{k}$  again contribute to the zero mode of  $\mathcal{E}_{(3/2,3/2)}$ , this time with exponentially decreasing factors proportional to  $e^{-4\pi \hat{k} \Omega_2}$ .

The above features were obtained by extending previous work on the duality between the four-graviton scattering amplitude of eleven-dimensional supergravity compactified on  $\mathcal{T}^2$  with the amplitude in type IIB string theory. In particular, we extended the work of [10] which deduced the dilaton-dependent prefactor,  $Z_{5/2}$  of the  $l_s^2 D^4 \mathcal{R}^4$  interaction from the low energy limit of two-loop effects in eleven dimensions. In this paper we extracted the next term in the momentum expansion of two-loop eleven-dimensional supergravity on a circle (to get to IIA) as well as on  $\mathcal{T}^2$  (to get to IIB). In both cases the string theory terms we are interested in emerge in the zero volume limit ( $R_{11} \rightarrow 0$  for IIA and  $\mathcal{V} \rightarrow 0$  for IIB). Although the tree-level IIA string amplitude is obtained by this procedure, the

loop corrections arise from undetermined divergent contributions. In contrast, the full modular function of the IIB theory is determined entirely by finite integrals (whereas in [10] we needed to consider a particular subdivergence). However, it is well known that the four-graviton amplitudes in the IIA and IIB string theories have the same perturbative expansion, at least up to two loops (beyond that there is the possibility of contributions from odd-odd spin structures that have opposite signs in the two theories). Therefore, the perturbative terms in the  $D^6 \mathcal{R}^4$  interaction of the IIA theory are determined once they are given in the IIB theory.

We also argued that the structure of the Laplace equation is intuitively that expected from a generalization of the supersymmetry arguments in [6], which determined the coefficient of  $\mathcal{R}^4$ . The source term in the Laplace equation,  $Z_{3/2}^2$  arises from the fact that terms in effective action of the same order as  $l_s^2 D^6 \mathcal{R}^4$  are not only related by supersymmetry to the classical action but also to  $l_s^{-2} \mathcal{R}^4$  and associated terms of the same dimension. It would be good to make this argument more precise. Following this line of reasoning, at the next order in  $l_s$  supersymmetry cannot mix the  $l_s^6 D^8 \mathcal{R}^4$  with anything and its prefactor should satisfy a homogeneous Laplace equation with solution  $Z_{7/2}$ . However, as argued in section 6, at the next order another inhomogeneous Laplace equation, with source  $Z_{3/2} Z_{5/2}$  (6.3), should determine the dilaton-dependent prefactor  $\mathcal{E}_{(3/2,5/2)}$  of the  $l_s^8 D^{10} \mathcal{R}^4$  interaction. The order after that reveals new systematics. This is the first time that two distinct terms in the expansion of the tree-level amplitude contribute – one with coefficient  $\zeta(9)$  and the other  $\zeta(3)^3$ . This presumably indicates a branching, with two distinct modular functions arising in the prefactor. It is clearly of interest to study systematics of the exact four-graviton amplitude at this order and beyond.

Finally, let us comment on the eleven-dimensional limit. In the case of the  $\mathcal{R}^4$  interaction the eleven-dimensional limit was determined entirely in terms of the coefficient of the one-loop amplitude [25]. Similarly the value of the eleven-dimensional limit of the  $D^6 \mathcal{R}^4$  interaction is determined by the two-loop contribution in the IIA theory. Since this is the same as the two-loop contribution to the IIB theory it is given by the  $\Omega_2^{-1}$  term in  $\mathcal{E}_{(3/2,3/2)}$ . Making use of the dictionary in appendix B and the fact that the IIA two-loop term is of order  $R_{11}^3$  results in the contribution to the eleven-dimensional action,

$$S = l_{11}^3 \frac{\zeta(2)^2}{120 \cdot (4\pi)^7} \int d^{11}x \sqrt{-G} D^6 \mathcal{R}^4. \tag{7.1}$$

The fact that the  $D^6 \mathcal{R}^4$  interaction has a finite eleven-dimensional limit whereas the  $D^4 \mathcal{R}^4$  interaction is absent in eleven dimensions is in accord with analogous statements concerning powers of the curvature. The first power of  $\mathcal{R}$  after  $\mathcal{R}^4$  that contributes in eleven dimensions was conjectured in [21] to be  $\mathcal{R}^7$ , which has the same dimension as  $D^6 \mathcal{R}^4$ . This seems also to be in accord with a very mysterious observation of [26] based on representations of  $E_{10}$ .

### Acknowledgments

We are grateful to Savdeep Sethi for useful insights into the role of supersymmetry and to Lance Dixon and David Kosower for conversations on higher-loop supergravity. P.V.

thanks the LPTHE of Jussieu for hospitality when this work was done. P.V. was partially supported by EU Research Training Networks MRTN-CT-2004-503369 and MRTN-CT-2004-005104 and MBG by MRTN-CT-2004-512194.

### A. Review of tree-level string amplitude and expansion of $Z_s(\Omega, \bar{\Omega})$

(i) **Tree-level four graviton scattering in type II string theory.** The amplitude has the form [27, 28],

$$A_4^{(2)} = \kappa_{10}^2 \hat{K} e^{-2\phi} T(s, t, u) \tag{A.1}$$

where  $2\kappa_{10}^2 = (2\pi)^7 l_s^8$  and  $T(s, t, u)$  is given by

$$\begin{aligned} T &= \frac{64}{l_s^6 stu} \frac{\Gamma(1 - \frac{l_s^2}{4}s)\Gamma(1 - \frac{l_s^2}{4}t)\Gamma(1 - \frac{l_s^2}{4}u)}{\Gamma(1 + \frac{l_s^2}{4}s)\Gamma(1 + \frac{l_s^2}{4}t)\Gamma(1 + \frac{l_s^2}{4}u)} \\ &= \frac{64}{l_s^6 stu} \exp\left(\sum_{n=1}^{\infty} \frac{2\zeta(2n+1)}{2n+1} \frac{l_s^{4n+2}}{4^{2n+1}} (s^{2n+1} + t^{2n+1} + u^{2n+1})\right). \end{aligned} \tag{A.2}$$

The low energy expansion of the amplitude begins with the terms, (making use of some identities proved in section 2 of [14])

$$\begin{aligned} T &= \frac{64}{l_s^6 stu} + 2\zeta(3) + \frac{\zeta(5)}{16} l_s^4 (s^2 + t^2 + u^2) \\ &+ \frac{\zeta(3)^2}{96} l_s^6 (s^3 + t^3 + u^3) + \frac{\zeta(7)}{512} l_s^8 (s^2 + t^2 + u^2)^2 + \frac{\zeta(3)\zeta(5)}{1280} l_s^{10} (s^5 + t^5 + u^5) + \\ &+ \frac{\zeta(9)}{4096} l_s^{12} \left(\frac{2}{81}(s^6 + t^6 + u^6) + \frac{7}{108}(s^2 + t^2 + u^2)^3\right) + \\ &+ \frac{\zeta(3)^3}{4096} l_s^{12} \frac{4}{27}(s^2 + t^2 + u^2)^3 + \dots \end{aligned} \tag{A.3}$$

For our considerations it is notable that the  $l_s^6 \zeta(3)^2 (s^3 + t^3 + u^3)$  term is the first that is not linear in the exponent of (A.2). Also, note that the first degeneracy of terms at a given dimension arises at order  $l_s^{12}$ , where there is a contribution with coefficient  $\zeta(9)$  and one with coefficient  $\zeta(3)^3$ .

In terms of the coordinates of the eleven-dimensional theory [10] the expression (A.3) has the low-energy expansion,

$$\begin{aligned} \frac{T}{R_{11}^3} &= \frac{64}{l_{11}^6 STU} + \frac{2\zeta(3)}{R_{11}^3} + \frac{\zeta(5)}{16} \frac{l_{11}^4}{R_{11}^5} (S^2 + T^2 + U^2) + \\ &+ \frac{\zeta(3)^2}{96} \frac{l_{11}^6}{R_{11}^6} (S^3 + T^3 + U^3) + \frac{\zeta(7)}{512} \frac{l_{11}^8}{R_{11}^7} (S^2 + T^2 + U^2)^2 + \\ &+ \frac{\zeta(3)\zeta(5)}{1280} \frac{l_{11}^{10}}{R_{11}^8} (S^5 + T^5 + U^5) + \\ &+ \frac{\zeta(9)}{4096} \frac{l_{11}^{12}}{R_{11}^9} \left(\frac{2}{81} (S^6 + T^6 + U^6) + \frac{7}{108} (S^2 + T^2 + U^2)^3\right) + \\ &+ \frac{\zeta(3)^3}{4096} \frac{l_{11}^{12}}{R_{11}^9} \left(\frac{4}{27} (S^2 + T^2 + U^2)^3\right) \dots \end{aligned} \tag{A.4}$$



(ii) **Expansion of the non-holomorphic Eisenstein series**  $Z_s(\Omega, \bar{\Omega})$ . For general values of  $s$  the expression (1.3) can be expanded as a Fourier series,

$$Z_s(\Omega, \bar{\Omega}) = \sum_k \mathcal{Z}_k^s e^{2\pi i k \Omega_1}, \quad (\text{A.5})$$

where

$$\mathcal{Z}_0^s = 2\zeta(2s)\Omega_2^s + 2\sqrt{\pi}\Omega_2^{1-s} \frac{\Gamma(s - \frac{1}{2})\zeta(2s-1)}{\Gamma(s)} \quad (\text{A.6})$$

and

$$\mathcal{Z}_k^s = \frac{4\pi^s}{\Gamma(s)} |k|^{s-\frac{1}{2}} \mu(k, s) \Omega_2^{\frac{1}{2}} \mathcal{K}_{s-\frac{1}{2}}(2\pi|k|\Omega_2) e^{2\pi i k \Omega_1}, \quad (\text{A.7})$$

with

$$\mu(k, s) = \sum_{\hat{m}|k} \hat{m}^{-2s+1}. \quad (\text{A.8})$$

The modified Bessel function  $\mathcal{K}_s$  has the integral representation

$$\mathcal{K}_s(z) = \frac{1}{2} \left(\frac{z}{2}\right)^s \int_0^\infty \frac{dt}{t} t^{-s} e^{-t-z^2/4t} \quad (\text{A.9})$$

and the asymptotic expansion for large  $z$ ,

$$\mathcal{K}_s(z) = \left(\frac{\pi}{2z}\right)^{1/2} e^{-z} \sum_{k=0}^{\infty} \frac{1}{(2z)^k} \frac{\Gamma(s+k+\frac{1}{2})}{\Gamma(k+1)\Gamma(s-k+\frac{1}{2})}. \quad (\text{A.10})$$

Substituting this expansion in (A.5)–(A.7) leads to the series (1.5).

## B. The dictionary between supergravity and superstring theories

In order to compare the results obtained from compactified eleven-dimensional supergravity with those of the IIA or IIB string theories we here review the dictionary that relates the parameters in the various descriptions. Compactification on a circle of radius  $R_{11}$  gives rise to the type IIA string theory where the string coupling constant,  $g^A = e^{\phi^A}$  (where  $\phi^A$  is the IIA dilaton), is given by  $l_{11} = (g^A)^{1/3} l_s$  and  $R_{11}^3 = e^{2\phi^A} = (g^A)^2$ . Masses are measured with the metric [29]

$$ds^2 = G_{MN}^{(11)} dx^M dx^N = \frac{l_{11}^2}{l_s^2 R_{11}} g_{\mu\nu} dx^\mu dx^\nu + R_{11}^2 l_{11}^2 (dx^{11} - C_\mu dx^\mu)^2, \quad (\text{B.1})$$

where  $g_{\mu\nu}$  is the string frame metric. Since the compactification radius  $R_{11}$  depends on the string coupling constant the Kaluza-Klein modes are mapped to the massless fundamental string states and the non-perturbative D0-brane states. When expressed in terms of the type IIA string theory parameters the compactified classical action becomes

$$S_{EH} = \frac{1}{2\kappa_{10}^2} \int d^{10}x \sqrt{-g} e^{-2\phi^A} R, \quad (\text{B.2})$$

where  $2\kappa_{10}^2 = (2\pi)^7 l_s^8$  and  $l_s$  is the string length scale.<sup>12</sup>

<sup>12</sup>In this convention the fundamental string tension is related to the string scale by  $T_F^2 = \pi(2\pi l_s)^4 / \kappa_{10}^2$ .

More generally, we want to consider compactification of the eleven-dimensional theory on a two-torus of volume  $\mathcal{V}$  and complex structure  $\Omega$  and compare with type IIA string theory compactified on a circle of radius  $r_A$  and type IIB compactified on a circle of radius  $r_B = 1/r_A$  (where these radii are dimensionless quantities that are defined in the respective string frames). The dictionary that relates  $\mathcal{V}$  and  $\Omega$  to the nine-dimensional type IIA and type IIB string theory parameters is [8, 9],

$$\begin{aligned} \mathcal{V} &= R_{10}R_{11} = \exp\left(\frac{1}{3}\phi^B\right) r_B^{-\frac{4}{3}}, & r_B &= \frac{1}{R_{10}\sqrt{R_{11}}} = r_A^{-1}, \\ \Omega_1 &= C^{(0)} = C_9^{(1)}, & \Omega_2 &= \frac{R_{10}}{R_{11}} = \exp(-\phi^B) = r_A \exp(-\phi^A). \end{aligned} \quad (\text{B.3})$$

The one-form  $C^{(1)}$  and the zero-form  $C^{(0)}$  are the respective  $R \otimes R$  potentials and  $\phi^A, \phi^B$  are the IIA and IIB dilatons.

In the text we use this dictionary to convert the leading contribution to the effective  $D^6 \mathcal{R}^4$  M-theory action in the limit  $\mathcal{V} \rightarrow 0$ , which behaves as  $\mathcal{V}^{-3}$ , to the corresponding action of ten-dimensional type IIB string theory, which is a finite quantity in the  $\mathcal{V} \rightarrow 0$  limit.

## C. Laplace equations

### C.1 Laplace equation for $A(\tau, \bar{\tau})$

In this section we derive the Laplace equation (3.12) satisfied by  $A(\tau) = \hat{A}(|\tau_1| + i\tau_2)$  defined in (3.11). We consider the following integral over the fundamental domain for  $Sl(2, \mathbf{Z})$

$$I = \int_{\mathcal{F}} \frac{d^2\tau}{\tau_2^2} A(\tau) \Delta_{\tau} F(\tau, \bar{\tau}), \quad (\text{C.1})$$

where  $F(\tau, \bar{\tau})$  is an arbitrary modular invariant function, exponentially decreasing for  $\tau_2 \rightarrow \infty$  (which is the case for  $\exp(-\pi E)$  in (3.10) for non vanishing  $m$  and  $n$ ). Integrating by part one should pay attention to the fact that because of the absolute value on  $\tau_1$  there are boundary contributions from  $\tau_1 = 0$ . Therefore one gets,

$$\begin{aligned} I &= \int_{\mathcal{F}} \frac{d^2\tau}{\tau_2^2} \Delta_{\tau} A(\tau) F(\tau, \bar{\tau}) + \\ &+ \int_{\partial_{\tau_1} \mathcal{F}} d^2\tau [-\partial_{\tau_1} A(\tau) F(\tau, \bar{\tau}) + A(\tau) \partial_{\tau_1} F(\tau, \bar{\tau})] + \\ &+ \int_{\partial_{\tau_2} \mathcal{F}} d^2\tau [-\partial_{\tau_2} A(\tau) F(\tau, \bar{\tau}) + A(\tau) \partial_{\tau_2} F(\tau, \bar{\tau})]. \end{aligned} \quad (\text{C.2})$$

By modular invariance and the fact that  $F(\tau)$  is exponentially decreasing for  $\tau_2 \rightarrow \infty$ , the  $\tau_2$ -boundary  $\partial_{\tau_2} \mathcal{F}$  does not contribute. From the  $\tau_1$ -boundary, the modular properties of  $A$  assures that only the boundary  $\tau_1 = 0$  contributes, and

$$\begin{aligned} \delta I &= -12 \int_1^{\infty} d\tau_2 \delta(\tau_1) \left(-\frac{1}{\tau_2}\right) F(\tau, \bar{\tau}) \\ &= -12 \int_{\mathcal{F}} \frac{d^2\tau_2}{\tau_2^2} \tau_2 \delta(\tau_1) F(\tau, \bar{\tau}). \end{aligned} \quad (\text{C.3})$$

In the interior of the fundamental domain where  $\tau_1 \neq 0$  one easily derives that  $\Delta_\tau A(\tau) = \Delta_\tau \hat{A}(\tau) = 12 A(\tau)$  Therefore the integral  $I$  is given by

$$I = \int_{\mathcal{F}} \frac{d^2\tau}{\tau_2^2} (12 A - 12\tau_2 \delta(\tau_1)) \overline{F(\tau, \bar{\tau})}. \quad (\text{C.4})$$

### C.2 Laplace equation for $\mathcal{Z}_{(s,s)}$

Equation (5.35) is obtained by first noting the following identities,

$$\begin{aligned} \Omega_2 \partial_\Omega Z_s^{(\hat{m}_I)} &= \frac{s}{2i} \frac{\Omega_2^s}{|\hat{m}_1 + \hat{m}_2 \Omega|^{2s}} \frac{\hat{m}_1 + \hat{m}_2 \bar{\Omega}}{\hat{m}_1 + \hat{m}_2 \Omega} \\ \Omega_2 \bar{\partial}_{\bar{\Omega}} Z_s^{(\hat{m}_I)} &= -\frac{s}{2i} \frac{\Omega_2^s}{|\hat{m}_1 + \hat{m}_2 \Omega|^{2s}} \frac{\hat{m}_1 + \hat{m}_2 \Omega}{\hat{m}_1 + \hat{m}_2 \bar{\Omega}}, \end{aligned} \quad (\text{C.5})$$

and

$$(\hat{m}_1 + \hat{m}_2 \Omega)^2 (\hat{n}_1 + \hat{n}_2 \bar{\Omega})^2 + c.c. = 2|\hat{m}_1 + \hat{n}_2 \Omega|^2 |\hat{n}_1 + \hat{n}_2 \Omega|^2 - 4(\hat{m}_1 \hat{n}_2 - \hat{n}_1 \hat{m}_2)^2 \Omega_2^2, \quad (\text{C.6})$$

where the quantity  $Z_s^{(\hat{m}_I)}$  is defined in (5.14). It follows that

$$\Delta_\Omega (Z_s^{(\hat{m}_I)} Z_{s'}^{(\hat{n}_I)}) = (s + s')(s + s' - 1) Z_s^{(\hat{m}_I)} Z_{s'}^{(\hat{n}_I)} - 4ss' (\det M)^2 Z_{s+1}^{(\hat{m}_I)} Z_{s'+1}^{(\hat{n}_I)}, \quad (\text{C.7})$$

so that, after multiplying by  $(\det M)^{s+s'}$  and summing over the integers  $\hat{m}_1, \hat{m}_2, \hat{n}_1$  and  $\hat{n}_2$ , the generalized series  $\mathcal{Z}_{(s,s')}$  defined in (5.18) is found to satisfy the differential equation (5.35),

$$\Delta_\Omega \mathcal{Z}_{(s,s')} = (s + s')(s + s' - 1) \mathcal{Z}_{(s,s')} - 4ss' \mathcal{Z}_{(s+1,s'+1)}. \quad (\text{C.8})$$

### C.3 Laplace equation for the lattice sum

We here produce some details of the calculations used in the main body of the text. The exponent has the expansion

$$\begin{aligned} E &= \frac{\mathcal{V}V}{\Omega_2 \tau_2} |(1 \ \Omega) M (\tau \ 1)|^2 + 2\mathcal{V}V \det M \\ &= \frac{\mathcal{V}V}{\Omega_2 \tau_2} [ |m_1 + m_2 \Omega|^2 + |\tau|^2 |n_1 + n_2 \Omega|^2 + 2\tau_1 ((n_1 + n_2 \Omega_1)(m_1 + m_2 \Omega_1) + n_2 m_2 \Omega_2^2) ]. \end{aligned} \quad (\text{C.9})$$

We will write

$$E = \frac{X}{\tau_2}, \quad (\text{C.10})$$

so that

$$\partial_{\tau_1}^2 E = \frac{\partial_{\tau_1}^2 X}{\tau_2} \quad \partial_{\tau_2} E = -\frac{E}{\tau_2} + \frac{1}{\tau_2} \partial_{\tau_2} X, \quad \partial_{\tau_2}^2 E = \frac{2}{\tau_2^2} (E - \partial_{\tau_2} X), \quad (\text{C.11})$$

where

$$\partial_{\tau_2} X = \frac{2\mathcal{V}V}{\tau_2} \tau_2 |n_1 + n_2 \Omega|^2. \quad (\text{C.12})$$

As a result we have

$$\begin{aligned} \tau_2^2 \partial_\tau^2 E &= 2E - 2\partial_{\tau_2} X + \tau_2^2 \partial_{\tau_1}^2 X = 2E, \\ \tau_2^2 \partial_\tau E \cdot \partial_\tau E &= E^2 + (\partial_{\tau_1} X)^2 + (\partial_{\tau_2} X)^2 - 2E \partial_{\tau_2} X = E^2 - 4\mathcal{V}^2 V^2 (\det M)^2, \end{aligned} \quad (\text{C.13})$$

where the explicit form of  $E$  has been used on the right-hand side of these equations, Therefore, we have that

$$\Delta_{\Omega} e^{-\pi E} \equiv 4\Omega_2^2 \partial_{\Omega} \partial_{\bar{\Omega}} e^{-\pi E} = \pi E^2 - 2\pi E - (2\mathcal{V}V \det M)^2, \quad (\text{C.14})$$

as quoted in the text.

## References

- [1] Z. Bern, L.J. Dixon, D.C. Dunbar, M. Perelstein and J.S. Rozowsky, *On the relationship between Yang-Mills theory and gravity and its implication for ultraviolet divergences*, *Nucl. Phys. B* **530** (1998) 401 [[hep-th/9802162](#)]; *Perturbative relationships between QCD and gravity and some implications*, [hep-th/9809163](#).
- [2] M.B. Green and M. Gutperle, *Effects of D-instantons*, *Nucl. Phys. B* **498** (1997) 195 [[hep-th/9701093](#)].
- [3] M.B. Green, M. Gutperle and P. Vanhove, *One loop in eleven dimensions*, *Phys. Lett. B* **409** (1997) 177 [[hep-th/9706175](#)].
- [4] M.B. Green, M. Gutperle and H.h. Kwon,  $\lambda^{16}$  and related terms in M-theory on  $T^2$ , *Phys. Lett. B* **421** (1998) 149 [[hep-th/9710151](#)].
- [5] M.B. Green, M. Gutperle and H.H. Kwon, *Light-cone quantum mechanics of the eleven-dimensional superparticle*, *JHEP* **08** (1999) 012 [[hep-th/9907155](#)].
- [6] M.B. Green and S. Sethi, *Supersymmetry constraints on type-IIB supergravity*, *Phys. Rev. D* **59** (1999) 046006 [[hep-th/9808061](#)].
- [7] A. Sinha, *The  $\hat{G}^4 \lambda^{16}$  term in IIB supergravity*, *JHEP* **08** (2002) 017 [[hep-th/0207070](#)].
- [8] P.S. Aspinwall, *Some relationships between dualities in string theory*, *Nucl. Phys.* **46** (*Proc. Suppl.*) (1996) 30 [[hep-th/9508154](#)].
- [9] J.H. Schwarz, *The power of M-theory*, *Phys. Lett. B* **367** (1996) 97 [[hep-th/9510086](#)].
- [10] M.B. Green, H.-h. Kwon and P. Vanhove, *Two loops in eleven dimensions*, *Phys. Rev. D* **61** (2000) 104010 [[hep-th/9910055](#)].
- [11] E. D'Hoker and D.H. Phong, *Two-loop superstrings, VI. Non-renormalization theorems and the 4-point function*, *Nucl. Phys. B* **715** (2005) 3 [[hep-th/0501197](#)]; *Two-loop superstrings, V. Gauge slice independence of the n-point function*, *Nucl. Phys. B* **715** (2005) 91 [[hep-th/0501196](#)]; *Two-loop superstrings, IV. The cosmological constant and modular forms*, *Nucl. Phys. B* **639** (2002) 129 [[hep-th/0111040](#)]; *Two-loop superstrings, III. Slice independence and absence of ambiguities*, *Nucl. Phys. B* **636** (2002) 61 [[hep-th/0111016](#)]; *Two-loop superstrings, II. the chiral measure on moduli space*, *Nucl. Phys. B* **636** (2002) 3 [[hep-th/0110283](#)]; *Two-loop superstrings, I. Main formulas*, *Phys. Lett. B* **529** (2002) 241 [[hep-th/0110247](#)].
- [12] R. Iengo, *Computing the  $R^4$  term at two super-string loops*, *JHEP* **02** (2002) 035 [[hep-th/0202058](#)].
- [13] N. Berkovits, *Multiloop amplitudes and vanishing theorems using the pure spinor formalism for the superstring*, *JHEP* **09** (2004) 047 [[hep-th/0406055](#)].

- [14] M.B. Green and P. Vanhove, *The low energy expansion of the one-loop type-II superstring amplitude*, *Phys. Rev.* **D 61** (2000) 104011 [[hep-th/9910056](#)].
- [15] E. D'Hoker, M. Gutperle and D.H. Phong, *Two-loop superstrings and S-duality*, *Nucl. Phys.* **B 722** (2005) 81 [[hep-th/0503180](#)].
- [16] E. D'Hoker and D.H. Phong, *Lectures on two-loop superstrings*, [hep-th/0211111](#).
- [17] Z.G. Xiao and C.-J. Zhu, *Factorization and unitarity in superstring theory*, *JHEP* **08** (2005) 058 [[hep-th/0503248](#)];  
W.J. Bao and C.-J. Zhu, *Comments on two-loop four-particle amplitude in superstring theory*, *JHEP* **05** (2003) 056 [[hep-th/0303152](#)];  
Z.J. Zheng, J.-B. Wu and C.-J. Zhu, *Two-loop superstrings in hyperelliptic language, III: the four-particle amplitude*, *Nucl. Phys.* **B 663** (2003) 95 [[hep-th/0212219](#)];  
Z.J. Zheng, J.B. Wu and C.-J. Zhu, *Two-loop superstrings in hyperelliptic language, II. The vanishing of the cosmological constant and the non-renormalization theorem*, *Nucl. Phys.* **B 663** (2003) 79 [[hep-th/0212198](#)]; *Two-loop superstrings in hyperelliptic language, I: the main results*, *Phys. Lett.* **B 559** (2003) 89 [[hep-th/0212191](#)].
- [18] N. Berkovits, *Super-Poincaré covariant two-loop superstring amplitudes*, [hep-th/0503197](#).
- [19] N. Berkovits and C.R. Mafra, *Equivalence of two-loop superstring amplitudes in the pure spinor and rns formalisms*, [hep-th/0509234](#).
- [20] J.G. Russo, *Construction of  $SL(2, \mathbb{Z})$  invariant amplitudes in type-IIB superstring theory*, *Nucl. Phys.* **B 535** (1998) 116 [[hep-th/9802090](#)].
- [21] J.G. Russo and A.A. Tseytlin, *One-loop four-graviton amplitude in eleven-dimensional supergravity*, *Nucl. Phys.* **B 508** (1997) 245 [[hep-th/9707134](#)].
- [22] A. Terras, *Harmonic analysis on symmetric spaces and applications I & II*, Springer-Verlag 1985.
- [23] Tom M. Apostol, *Introduction to analytic number theory*, Springer-Verlag, New York, 1976.
- [24] M. Matone and R. Volpato, *Higher genus superstring amplitudes from the geometry of moduli spaces*, [hep-th/0506231](#).
- [25] M.B. Green and P. Vanhove, *D-instantons, strings and M-theory*, *Phys. Lett.* **B 408** (1997) 122 [[hep-th/9704145](#)].
- [26] T. Damour and H. Nicolai, *Higher order M-theory corrections and the kac-moody algebra  $E_{10}$* , *Class. and Quant. Grav.* **22** (2005) 2849 [[hep-th/0504153](#)].
- [27] M.B. Green and J.H. Schwarz, *Supersymmetrical dual string theory, 2. Vertices and trees*, *Nucl. Phys.* **B 198** (1982) 252.
- [28] M.B. Green, J.H. Schwarz and E. Witten, *Superstring theory*, Cambridge University Press 1987.
- [29] E. Witten, *String theory dynamics in various dimensions*, *Nucl. Phys.* **B 443** (1995) 85 [[hep-th/9503124](#)].